



ORAC<sup>®</sup>  
D E C O R

*Reflecting*  
your  
*Imagination*

# Welcome to our World of Imagination



*Guy, Laurence & Yves Taillieu*

pl

Witamy w świecie marzeń  
ORAC<sup>®</sup>

Orac<sup>®</sup> tworzy międzynarodowe standardy jakości ornamentów 3d, będąc przy tym stale innowacyjnym w kwestii technologii, materiałów i wzorów. Efektem jest wszechstronna i kompletna kolekcja stworzona przez profesjonalistów, pasjonatów i kreatywnych specjalistów, którzy doceniają innowacyjność, wysoką jakość i łatwość instalacji produktów, umożliwiających im tworzenie inspirujących i niepowtarzalnych przestrzeni. Poczynając od listew przypodłogowych i profili oświetleniowych po profile wielofunkcyjne i realistyczne gzymsy wszystkie spełniają współczesne normy jakości dotyczące zarówno funkcjonalności jak i dekoracji.

Stosując produkty Orac<sup>®</sup> można każde pomieszczenie uczynić unikalnym, całkowicie zgodnym z Twoją osobowością i stylem, bez żadnych ograniczeń twórczych.

Witamy w naszym świecie.

**fr**

Bienvenue dans le monde merveilleux d'ORAC®

Orac® est la référence internationale pour les ornements 3D de grande qualité, innovant en permanence sur les plans de la technologie, des matériaux et du design. Avec pour résultat une collection complète réalisée par et pour des passionnés. Des professionnels à l'esprit créatif, qui aiment les produits de qualité innovants et faciles à installer, pour créer des espaces inspirants et uniques. Des plinthes et profils d'éclairage indirect aux corniches de caractère, en passant par les profils multifonctionnels. Des solutions de qualité actuelles, fonctionnelles et décoratives.

Avec Orac®, vous faites de chaque espace un lieu unique. En parfaite cohérence avec votre style et votre personnalité, sans aucune restriction créative.

Bienvenue dans notre monde.

**en**

Welcome to the dream world of ORAC®

Orac® is the international standard for quality 3D ornaments, innovating constantly in technology, materials and design. The result is a comprehensive and complete collection by and for passionate professionals. Creative professionals who appreciate innovation and quality products that are easy to install, enabling them to create inspiring and unique spaces. From skirting boards and indirect lighting profiles to multifunctional profiles and cornice mouldings with real character. Contemporary quality solutions that are both functional and decorative.

With Orac® you can make every room unique, entirely in line with your style and personality, without any creative restrictions.

Welcome to our world.

**ru**

Добро пожаловать в мир фантазий ORAC®

Orac® устанавливает международные стандарты для высококачественных 3D орнаментов. Компания постоянно создает инновации в технологиях, материале и дизайне. Результатом является полная коллекция, созданная творческими разработчиками для профессионалов. Коллекция, которая позволяет создать вдохновляющие и уникальные интерьеры: от плинтусов и профилей скрытого освещения до multifunctional орнаментов и карнизов с "характером". Современные и высококачественные решения, которые функциональны, а также украшают интерьер.

С помощью Orac® вы можете сделать каждую комнату уникальной, полностью в соответствии с вашим стилем и индивидуальностью, без каких-либо творческих ограничений.

Добро пожаловать в наш мир.

**ar**

مرحبا بكم في عالم أورك ديكور® السحري

أورك ديكور® هي المرجعية العالمية للقوالب الزخرفية الثلاثية الأبعاد العالية الجودة، دائمة الابتكار من حيث التكنولوجيا، المواد والتصميم. النتيجة هي تشكيلة كاملة مصنوعة من قبل ومن أجل محترفين مشغوفين. محترفون مبدعون يقدرون المنتجات المبتكرة العالية الجودة والسهولة التركيب، التي تمكنهم من خلق مساحات ملهمة وفريدة من نوعها. من النعلات والقوالب المحتوية على إضاءة غير مباشرة، إلى الكرائيش المميزة والقوالب المتعددة الإستعمالات. حلول معاصرة عالية الجودة، عملية وزينية.

مع أورك® يمكنكم جعل كل غرفة مكانا فريدا، يتماشى تماما مع أسلوب حياتكم وشخصيتكم، من دون أي قيود إبداعية.

مرحبا بكم في عالمنا.

*Reflecting*  
your  
*Imagination*

ORAC®  
DECOR





***Antonio***

Create a Ray of Light

# Our Design Favorites

2003

Myline



C353  
p. 82

Jacques Vergracht

2012

Golf



P3071  
p. 67

Ulf Moritz

2009

Infinity



C990  
p. 88

Xavier Donck

2009

High Heels



SX156  
p. 116

Xavier Donck

2011

Wave



C364  
p. 121

Pierre Daems  
Red Dot Design Award 2014

2012

Scala



G71  
p. 71

Ulf Moritz

2012

Shade



C371  
p. 66

Ulf Moritz

2011

Heritage



C343  
p. 90

Guy Taillieu

2011

Antonio



C374  
p. 68

Ulf Moritz



# Content

**10 Inspiring Interiors**

**62 Product Overview**

64 Ulf Moritz Collection

80 Cornice Mouldings

100 Panel Mouldings

112 Skirting

118 Indirect Lighting

126 Deco Elements

148 Adhesives & Accessories

**154 Project and Exterior Info**

**156 Technical Info**

<u>pl</u>	<u>fr</u>	<u>ru</u>	<u>ar</u>
<b>10 Inspirujące wnętrza</b>	<b>10 Intérieurs Inspirants</b>	<b>10 Вдохновляющие интерьеры</b>	<b>10 تصاميم داخلية ملهمة</b>
<b>62 Przegląd produktów</b>	<b>62 Aperçu produits</b>	<b>62 Обзор продукции</b>	<b>62 نظرة عامة على المنتجات</b>
64 Kolekcja Ulf Moritz	64 Ulf Moritz Collection	64 Ulf Moritz Collection	64 مجموعة أولف موريتز
80 Gzymsy	80 Corniches	80 Карнизы	80 كرائيش
100 Profile	100 Cimaises	100 Молдинги	100 قوالب للجدران
112 Listwy Przyścielone	112 Plinthes	112 Плинтусы	112 نعلات
118 Listwy Oświetleniowe	118 Éclairage Indirect	118 Скрытое Освещение	118 إضاءة غير مباشرة
126 Elementy Dekoracyjne	126 Éléments décoratifs	126 Декоративные элементы	126 أصناف للزينة
148 Kleje i Akcesoria	148 Colles et Accessoires	148 Клей И Инструменты	148 مواد لاصقة ولوازم
<b>154 Projekty i Instalacja na zewnątrz</b>	<b>154 Projet et Applications Extérieures</b>	<b>154 Проекты &amp; Наружное применение</b>	<b>154 مشروع &amp; إستعمال خارجي</b>
<b>156 Informacje techniczne</b>	<b>156 Installation</b>	<b>156 Техническая информация</b>	<b>156 معلومات تقنية</b>

3

4

### pl

Zastosowanie oszczędnych i prostych profili oraz elementów tworzących graficzne linie i wzory nadaje, widocznemu na zdjęciu wnętrzu pensjonatu, dodatkowych wrażeń i akcentów wizualnych. Jasne kolory na ścianach oraz wysokie listwy przypodłogowe pomalowane na ten sam kolor co drewniana podłoga tworzą klasyczny skandynawski nastrój: czysty, graficzny i stylowy.

### fr

La mise en place de motifs et de lignes graphiques par le biais d'éléments et de profils épurés et simples confère une dimension supplémentaire à l'intérieur de ce Bed & Breakfast. Les teintes claires sur le mur et la plinthe surélevée dans la salle à manger, peinte dans la couleur du parquet, évoquent la Scandinavie telle que nous la connaissons : pure, graphique et élégante.

### en

Applying simple, straight profiles and elements, graphic lines and patterns gives the interior of this bed and breakfast that extra touch of visual excitement. The light tones on the walls and the high skirting boards in the dining room, painted in the same colour as the wooden floor, give the room a classic Scandinavian ambience: clean, graphic and stylish.

1 G77 LILY p. 72

designed by Ulf Moritz



2 G78 LILY p. 72

designed by Ulf Moritz

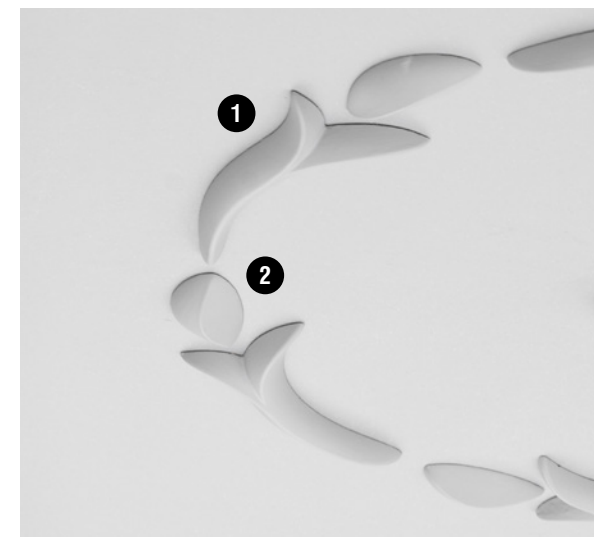

3 CB501 p. 97



4 DX157-2300 p. 114



5 CB503 p. 97



6 PX120 p. 106



7 R66 p. 138



8 DX163-2300 p. 115



9 DX162-2300 p. 106



Vemdalen  
— SE

# Hölm

“Clean, graphic lines –  
pure Scandinavian style”



## ru

Применение простых, гладких профилей и элементов, графических линий и узоров передают этому интерьеру дополнительный штрих визуального восхищения. Легкий тон стен и высокий плинтус в столовой, окрашенный в цвет деревянного пола, передают комнате классический Скандинавский стиль: безупречный, выразительный, элегантный.

## ar

إستعمال قوالب بسيطة وانيقة لخلق خطوط ونقشات جرافيكية تعطي داخل هذا المنزل بعدا إضافيا. الألوان الفاتحة على الحائط، والنحلة المرتفعة في غرفة الطعام والمطلية بنفس لون الأرضية الخشبية، تضيء على الغرفة جو إسكندنافي كلاسيكي: صافي، جرافيكي وأنيق.



# Hölm





1 R08 *p. 136*







2 CB503 *P. 97*



**Multi-Functionals**

DX157-2300 | DX157F  
 DX162-2300  
 DX163-2300  
 DX168-2300

<p>3 DX157-2300   DX157F <i>p. 107</i></p> 	<p>4 DX162-2300 <i>p. 106</i></p> 
<p>5 DX163-2300 <i>p. 107</i></p> 	<p>DX168-2300 <i>p. 116</i></p> 

# Artson

Cranleigh  
— UK



## pl

W tych pomieszczeniach angielski styl Heritage odtworzony jest w bardziej nowoczesny sposób. Obramowania paneli tworzące ekrany są zaaranżowane w oryginalny wzór, a imponujący, asymetryczny gzyms podkreśla optyczną iluzję. To wnętrze udowadnia, że wielki styl z mocną sztukaterią może się okazać ogromnym sukcesem.

## fr

Dans cette chambre, l'héritage anglais est ressuscité d'une manière contemporaine. Les cadres sur le mur sont placés dans un motif original et la corniche asymétrique imposante crée une illusion d'optique. Un intérieur qui démontre que créer un effet majestueux avec des profils massifs peut s'avérer une véritable réussite.

## en

English Heritage is recreated in a modern manner in this room. The framed panels on the wall are arranged in an original pattern, and the imposing asymmetrical cornice moulding creates an optical illusion. This interior shows that a grand style with strong mouldings can be enormously successful.

## ru

В этой комнате в современном стиле воссоздано "Английское наследие". Каркасные панели на стене расположены оригинальным узором. Внушительный ассиметричный карниз создает оптическую иллюзию. Этот интерьер демонстрирует, что замечательный стиль с решительными молдингами может иметь чрезвычайный успех.

## ar

في هذه الغرفة، أعيد خلق التراث الإنجليزي بطريقة عصريّة. الإطارات على الجدار والكورنيش المهيبة الغير متماثلة تخلق وهم بصري. هذا الداخل يثبت أن خلق طراز فخّم بواسطة قوالب ضخمة يمكن أن يكون ناجحاً جداً.



❶ C344 HERITAGE p. 91



❷ P8030 p. 102



❸ P8020 p. 103



❹ P4020 p. 102



❺ SX118 p. 116







1 P8020 p. 103



2 P4020 p. 102



# Artson

*“Grand style:  
a great success”*

C341 M

P. 84

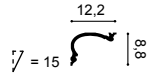

C342 L

P. 87



C343 XL

p. 90

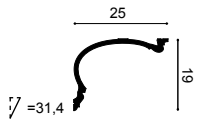

3 C344 XXL

p. 91

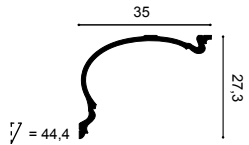

4 DX170-2300

p. 128

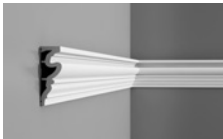

5 D330LR

p. 128

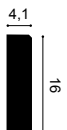

C341 M  
C342 L  
C343 XL  
C344 XXL  
DX170-2300  
D330LR

**The  
Heritage  
Collection**



Das  
**Tegernsee**  
Hotel

❶ PX120 p. 106



❷ P8020 p. 103



❸ PX103 p. 106



❹ SX137 p. 115



❺ CX124 p. 94

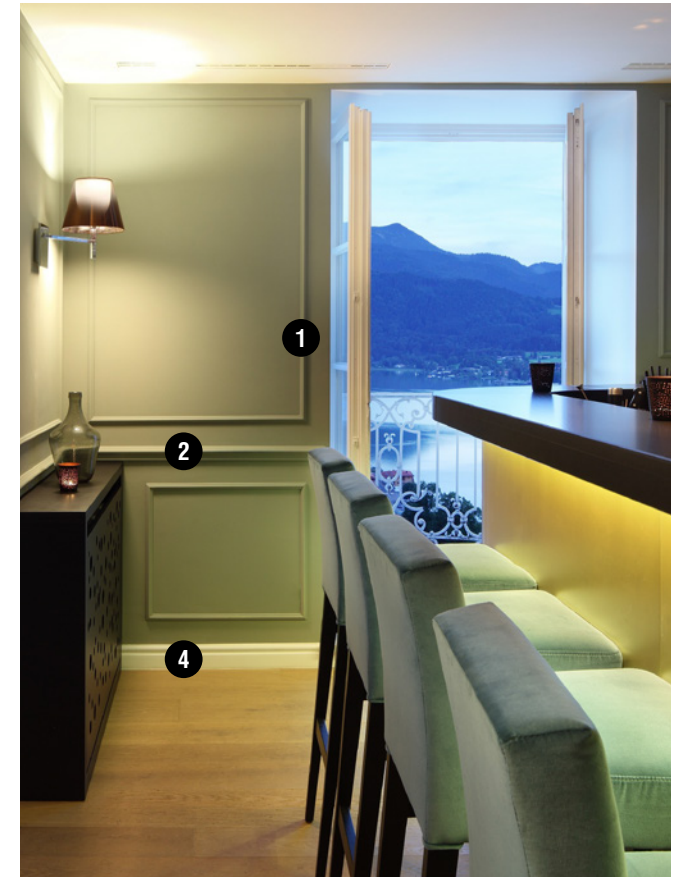

**Tegernsee**  
— DE

*"A room  
with a view"*



# Northsea Penthouse

**Oostende**  
— BE



*“Sometimes it complements the surroundings, sometimes it emphasizes them and sometimes it quietly merges into them – that is the essence of architecture”*

## pl

Zadanie polegało na wprowadzeniu do wnętrza charakterystycznego dla natury spokoju, kojarzącego się z wybrzeżem. Dlatego listwy zastosowane do wykończenia są dyskretne i niezauważalne w oczy, jedynie rozproszone oświetlenie tworzy lekką i przestronną atmosferę

## fr

L'objectif était simple : restituer à l'intérieur l'impression de calme évoqué par la nature et la mer. Les profils renforcent le concept intérieur sans se faire remarquer et l'éclairage indirect confère un caractère spacieux et lumineux à cet appartement situé sur la côte belge.

## en

The task was to bring the restful mood of nature and the seashore inside. The mouldings add to the interior without being conspicuous, and the indirect lighting gives this flat on the Belgian coast a light and roomy feel.

## ru

Задачей было представить внутреннее спокойствие природы и побережья. Молдинги сочетаются с интерьером, не привлекая внимания, а скрытое освещение придает этим апартаментам на побережье Бельгии легкость и простор.

## ar

كان الهدف جلب إنطباع هدوء الطبيعة والشاطئ الى الداخل. القوالب مدمجة في الداخل دون أن تكون بارزة، والإضاءة الغير مباشرة تعطي هذه الشقة على الساحل البلجيكي طابع فسيح ومضيء.

### 1 C357 STRAIGHT p. 120

designed by  
Jacques Vergachi

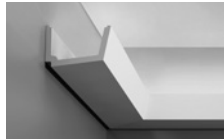

### 2 DX157-2300 p. 114



### 3 C354 p. 82

designed by  
Jacques Vergachi



### 4 DX163-2300 p. 115





**1** C990 INFINITY *p. 90*

designed by Xavier Donck



**2** SX156 HIGH HEELS *p. 116*

designed by Xavier Donck



**3** CX126 *p. 95*



**4** C362 CURVE *p. 121*

designed by Pierre Dumas

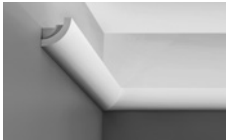

# Northsea Penthouse

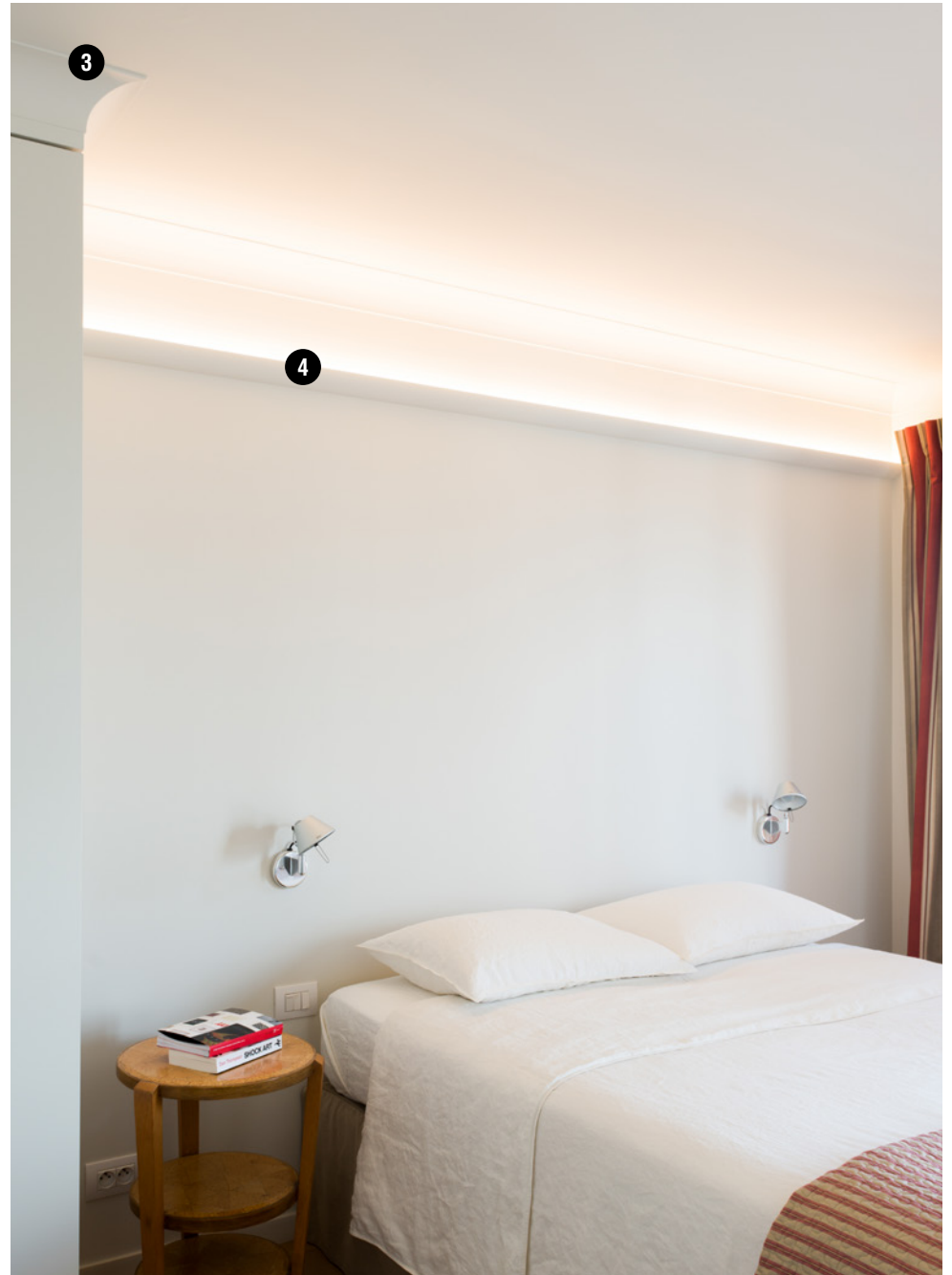



Den Haag  
— NL

# Clinic 28



**pl**

Naturalna aura wnętrza dostojnej willi „The Hague” została przywrócona dzięki zastosowaniu odpowiednich listew przypodłogowych, obramowań paneli oraz gzymsów. We wnętrzach obecnej kliniki kosmetycznej, piękno znajduje swój pełen wyraz w ciepłym i bezpiecznym otoczeniu.

**fr**

Le rayonnement authentique de cette villa majestueuse située à La Haye reprend ses droits grâce à l'utilisation de plinthes, de cadres et de corniches. Dans cette clinique esthétique, la beauté est transcendée dans un environnement chaleureux et intime.

**en**

The authentic aura of the interior of this stately villa in The Hague has been restored by fitting skirting boards, framed panels and cornice mouldings. In this cosmetic clinic, beauty finds its full expression in a warm, familiar surroundings.

**ru**

Подлинная аура этого интерьера величественной виллы в Гааге была дополнена плинтусами, каркасными панелями и карнизами. В этой косметической клинике красота находит своё полное выражение в теплой, уютной атмосфере.

**ar**

تمت إستعادة هالة هذه الفيلا في لاهاي بإستعمال نعلات، إطارات وكرانيش. في هذه العيادة التجميلية، يجد الجمال تعبيره الكامل في بيئة دافئة وحميمة.



**1** P8030 p. 102



**2** P8020 p. 103



**3** P8050 p. 105



**4** SX118 p. 116





# Clinic 28



❶ R40 *p. 139*



❷ P8030 *p. 102*



❸ C217 *p. 85*





*"A perfect reflection of the true and natural beauty of mouldings"*

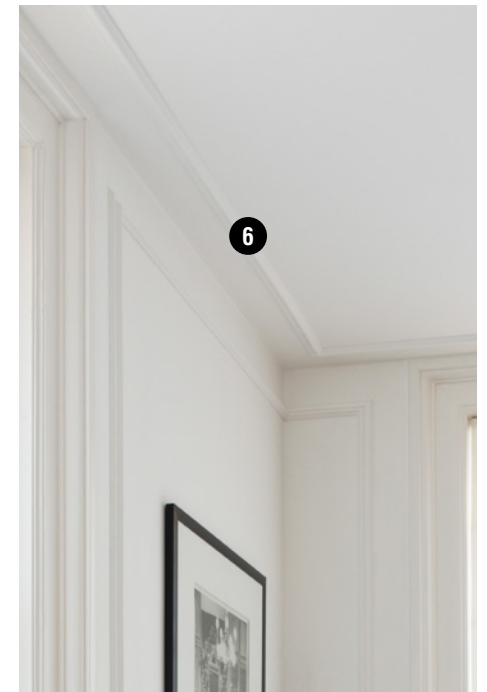

**4** P8050 p. 105



**5** SX118 p. 116



**6** PX103 p. 106





St. Petersburg  
— RU

# Metiendovivendum

1 SX118 p. 116



2 P8050 p. 105



3 D170 p. 132



4 P8030 | P8030F p. 102



5 P8020 | P8020F p. 103



6 P8050 | P8050F p. 105



7 SX118 | SX118F p. 116



8 C307 p. 90



*“Rooms that breathe history”*

— Sigisbert Engelbosch,  
Interior Designer

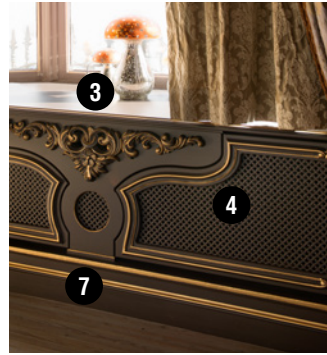



# *Manoir Fleuriri*

**Bordeaux**  
— FR





## pl

Barok powraca, ale to nie musi koniecznie oznaczać artystycznego przesytu – jak dowodzą zaprezentowane zdjęcia wnętrz. Inspirowane historycznym stylem, dekoracyjne sztukaterie i elementy narożne tworzą szykowane linie i cienie bez narzucania się.

## en

Baroque is back, but that does not necessarily mean artistic excess – as this interior demonstrates. The decorative mouldings and corner features, inspired by the past, generate an array of lines and shadows without being obtrusive.

## fr

Cet intérieur est la preuve que le retour du baroque n'est pas nécessairement synonyme d'excès. Les profils décoratifs et les éléments d'angle inspirés par le passé créent un jeu de lignes et d'ombres, sans se faire trop remarquer.

## ru

Этот интерьер - доказательство того, что возвращение Барокко не обязательно ассоциируется с избытком. Декоративные профили и угловые элементы, навеянные прошлым, ненавязчиво создают взаимодействие линий и теней.

## ar

هذا التصميم الداخلي يظهر أن عودة الباروك ليس بالضرورة مرادفا للإفراط. الزوايا والقوالب الزخرفية المستوحاة من الماضي تولد تأثيرا جميلا من الخطوط والظلال، دون أن تكون بارزة جدا.

1 C338A BA'ROCK p. 89



2 C338B BA'ROCK p. 89



3 P3020+P3020A p. 109

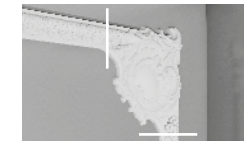

4 P8040 p. 104



5 P8020 p. 103



6 D62 p. 136



7 P8050 p. 105



8 SX118 p. 116



9 C338 p. 89





1 DX162-2300 p. 106



2 C353 p. 82



Designed by  
Jacques Vergnaud

# Lan Lan

Madrid  
— ES

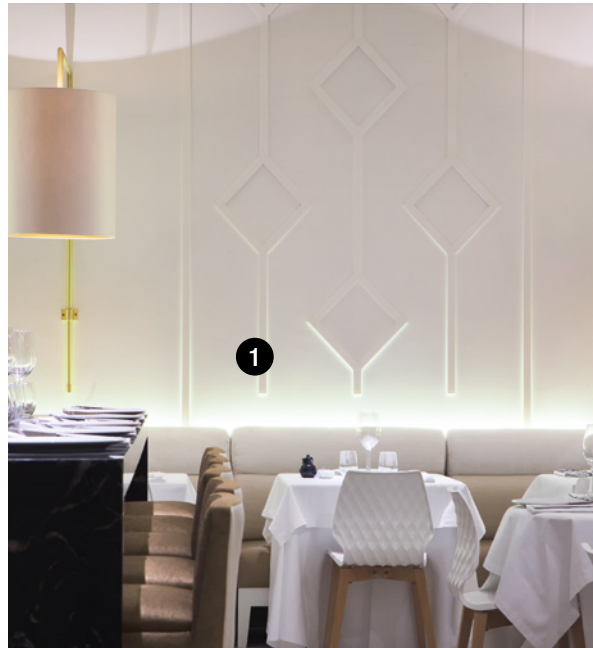

*“All it takes is one profile and a good deal of creativity to get to an extraordinary result”*



1 C901 p. 125



2 P8030 p. 102



# ***BDBA***

*“Fashion and interior  
design: a perfect fit”*



# Berto

Waregem  
— BE

**pl**

Wnętrze renomowanej restauracji Berto odzwierciedla fuzję charakteru klasycznego z dotykem nowoczesności. Perfekcyjnie wystylizowane podłóże w postaci białych ścian otrzymuje większą wyrazistość, dzięki zastosowaniu listew przypodłogowych oraz gzymsów o prostej i przejrzystej linii.

**fr**

L'intérieur du restaurant étoilé Berto reflète le caractère de sa cuisine : classique, agrémentée de touches modernes. La base élégante en blanc minimaliste est dynamisée par des plinthes et corniches épurées ; l'éclairage indirect crée quant à lui l'ambiance adéquate.

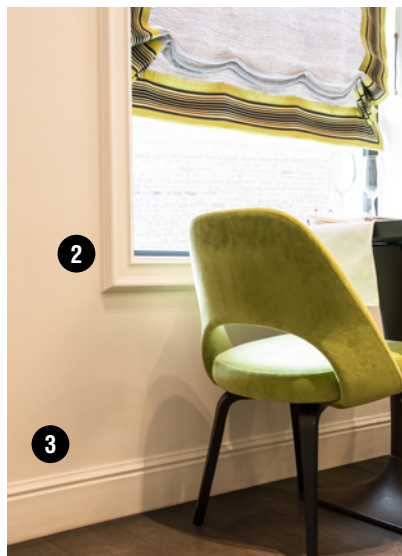



*“Orac Decor® profiles add extra flavor to clean and white spaces”*

**en**

The interior of the renowned Berto restaurant reflects the character of the cuisine: classical with a modern touch. The perfectly styled base in taut, clean white is given extra emphasis by skirting-boards and cornice mouldings with simple, clean lines, while the indirect lighting creates a suitable ambience.

**ru**

Интерьер в известном ресторане Berto отражает характер кухни: классическая с современным стилем. Стильный интерьер подчеркивают своими простыми линиями плинтусы и карнизы, в то время как скрытое освещение создает уютную атмосферу.

**ar**

داخل مطعم برتو الشهير يعكس طابع المطبخ: كلاسيكي مع لمسة عصرية. الخلفية البيضاء الأنيقة معززة بنعلات وكرانيش ذات خطوط نقية، والإضاءة غير المباشرة تخلق الجو المناسب.

**1** C336 *p. 91*



**2** DX121-2300 *p. 104*



**3** SX118 *p. 116*



**4** R09 *p. 137*



**5** C217 *p. 85*



**6** C901 *p. 125*



**7** R40 *p. 139*



# Eyes

## Nights Only

Kortrijk  
— BE





*“Raw meets design: ORAC hotel make-over”*

**1** C374 ANTONIO p. 68



**2** C373 ANTONIO p. 68

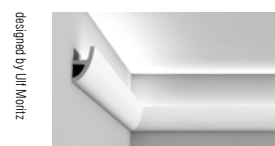

**3** C991 CURTAIN PR. p. 70



**4** P3070 RADIUS p. 67

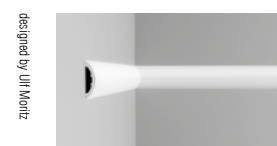

**5** C371 SHADE p. 66



**7** FOCUS R70 p. 71, 138



**6** SX156 HIGH HEELS p. 116





1

3

4

# Grayson Estate

The Hamptons  
— USA

1 SX118 p. 116



2 C334 p. 88



3 C333 p. 86



4 C331 p. 83







1 P9010 p. 104



2 P8020 p. 103



3 SX118 p. 116



4 C334 p. 88



5 C370 CLOUD p. 67



**pl**

Od dyskretnej elegancji do ekstrawagancji: w tym wyjątkowym projekcie wszystko jest dozwolone. Każde pomieszczenie opowiada własną historię. Rozproszone światło tworzy dodatkową przestrzeń pomiędzy ścianami, a sufitem. Zastosowana listwa Ulf Moritz „Cloud” doskonale rozświetla ciemne zasłony.

**fr**

De l'élégance pure à l'extravagance : dans ce projet unique, tous les registres sont ouverts. Chaque pièce raconte sa propre histoire. L'éclairage indirect forme un niveau supplémentaire du mur au plafond et le profil « Cloud » d'Ulf Moritz crée presque littéralement de l'air au-dessus des lourds rideaux.

**en**

From understated elegance to extravagance: all the stops are pulled out in this unique project. Every room tells its own story. The indirect lighting generates an extra level between the walls and the ceiling, and the Ulf Moritz "Cloud" moulding almost literally creates light above the dark curtains.

**ru**

От утонченной элегантности до экстравагантности: этот уникальный проект использует все стили. Каждая комната рассказывает свою историю. Скрытое освещение создает дополнительное пространство между стеной и потолком, а профиль "Cloud", разработанный дизайнером Ulf Moritz, буквально создает свет над темными шторами.

**ar**

من الأناقة الصرفة إلى الإسراف: في هذا المشروع الفريد من نوعه، جميع السجلات مفتوحة. كل غرفة تحكي قصتها الخاصة. الإضاءة غير المباشرة تشكل تدرج إضافي بين الجدران والسقف، وقالب "Cloud" من المصمم أولف موريتز يخلق هواءً فوق الستائر الثقيلة.

# Grayson Estate





1

2

2

**pl**

W tym czerwonym korytarzu kluczowym zagadnieniem jest głębia. Proste, równoległe linie, otaczające drzwi oraz rozproszone oświetlenie na suficie przekształcają ten ciemny korytarz w luminescencyjny tunel. Wrażenie głębi jest podkreślone i prowadzi wzrok w dal.

**fr**

La profondeur est le mot clé dans ce tunnel rouge. Les lignes convergentes épurées - qui encadrent également la porte - et l'éclairage indirect au plafond ont transformé ce couloir sombre en un tunnel luminescent. L'impression de profondeur est accentuée et attire l'attention vers l'horizon.

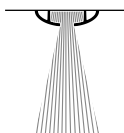

## Antonio Lighting Inspiration

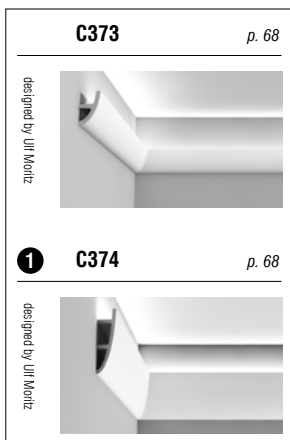

**en**

Depth is the keyword in this red tunnel. The straight converging lines, which also surround the door and the indirect lighting on the ceiling transform this dark passageway into a luminescent tunnel. Depth is emphasized and draws attention to the distant view.

**ru**

Глубина является ключевым словом в этой красной тунеле. Прямые, пересекающиеся линии, которые также обрамляют дверь и скрытое освещение, преобразуют темный проход в светящийся тунель. Подчеркивается ощущение глубины и внимание уходит на удаленный вид.

**ar**

العمق هو الكلمة الرئيسية في هذا النفق الأحمر. الخطوط المستقيمة المتقاربة، التي تحيط أيضا بالباب، والإضاءة غير المباشرة على السقف تحول هذا الممر المظلم إلى نفق مشع. الإحساس بالعمق يزداد ويلفت النظر إلى البعيد.

**2** DX168-2300 *p. 129*



# The Red

Milano  
— IT



*“Using ORAC’s versatile products we’ve recreated a classic style”*

— Beatriz Silvera,  
Spanish Interior designer

# Casa **Madrid** — ES *Decor*





## pl

Raz do roku wszyscy projektanci i pasjonaci wnętrz podążają do Casa Decor. Rezultatem zaskakującej kompozycji elementów, jest nowe życie tchnięte w ten stary budynek. Elementy sztukaterii Orac Decor® wnoszą wyjątkową wartość do gry kolorów, światła i faktur na sufitach, ścianach, a nawet meblach.

## fr

Une fois par an, tous les professionnels et amateurs de décoration d'intérieur viennent découvrir Casa Decor. Un ancien bâtiment y reprend vie, créant ainsi ce mariage surprenant. Le jeu de couleur, de lumière et de texture sur le plafond, les murs et même les meubles est particulièrement mis en valeur grâce aux profils et aux éléments Orac Decor®.

## en

Once a year all interior design professionals and enthusiasts make a pilgrimage to Casa Decor. New life is breathed into an old building, with this surprising mix as a result. The Orac Decor® mouldings and elements give a special touch to the play of colour, light and texture on the ceiling, walls, and even the furniture.

❶ C336 p. 91



❷ C201 p. 85



❸ P8030 p. 102



❹ SX118 p. 116



❺ DX157-2300 p. 107



❻ P8020 p. 103



❼ F30 p. 140



❽ H100 p. 133





**RU**

Раз в году все дизайнеры в сфере интерьера и энтузиасты совершают путешествие в Casa Decor. Старое здание снова оживает в результате этого смешивания. Взаимодействие цвета, света и фактуры на потолке, стенах и даже мебели получает особый колорит, благодаря молдингам и декоративным элементам Orac Decor.

**AR**

مرة في السنة، يأتي جميع المحترفين وهواة التصميم الداخلي لإكتشاف كازا ديكور. تنفخ حياة جديدة في مبنى قديم، وينتج عن ذلك هذا المزيج المدهش. قوالب أورك ديكور تضيف لمسة خاصة الى لعبة الألوان والضوء والملمس على السقف والجدران وحتى الأثاث.



1 C340 p. 91



2 D400 p. 132



3 K200+D320 p. 146

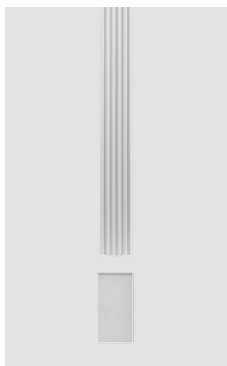

4 P8020 p. 83



5 SX138 p. 116



6 PX103 p. 106



7 PX102 p. 107



8 C217 p. 85



9 SX137 p. 115



# Casa Decor



7

8

9



1 C372 FLUXUS p. 66

designed by Ulf Moritz



2 P3071 GOLF p. 67

designed by Ulf Moritz



# Rabo | Amsterdam — NL Bank

*“The DNA of Orac Decor<sup>®</sup> profiles allowed us to create a homely feeling in a business environment”*

— MEMO, Interior Composers

*“A living Pinterest, there’s no better way to subscribe this showroom”*

**R** CEILING ROSES p. 136



**1** C371 SHADE p. 66



designed by Juri Moritz



# Pand

# 16

Sint-Niklaas  
— BE



*"Traditional luxury in a  
historic setting"*

# 't Goude Hoofst

Den Haag  
— NL





**1 P9010** p. 104



**2 P8030** p. 102



**3 SX118** p. 116



**4 C371 SHADE** p. 66



designed by Ulf Moritz

**5 G72 SMILE** p. 72



designed by Ulf Moritz

**6 G73 | G74 CURL** p. 72

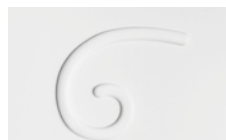

designed by Ulf Moritz



## pl

Dzięki zastosowaniu bogatej gamy sztukaterii Orac Decor® oraz elementów z kolekcji Ulf Moritz dom gościnny i stary zajazd The Hague witają swoich gości luksusem, bogactwem i pięknem.

## fr

Grâce à la combinaison abondante de profils Orac Decor® et d'éléments Ulf Moritz extravagants, les hôtes de la plus ancienne auberge de La Haye sont accueillis dans la beauté, le luxe et la volupté.

## en

Thanks to the rich mix of Orac Decor® mouldings and playful Ulf Moritz elements, hotel guests at the oldest inn of The Hague are welcomed in luxury, opulence and beauty.

## ru

Благодаря обильному сочетанию молдингов Orac Decor® и игривым элементам Ulf Moritz, в самом старом отеле Гааги гостей приветствовали в роскоши, богатстве и красоте.

## ar

بفضل مزيج غني من قوالب أوراك ديكور® وأصناف المصمم أولف موريتز، يستقبل نزلاء أقدم فندق في لاهاي في الترف، الرخاء والجمال.

1 P3070 RADIUS p. 67

designed by Ulf Moritz

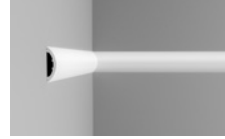

2 C370 CLOUD p. 67

designed by Ulf Moritz



3 P3071 GOLF p. 67

designed by Ulf Moritz



*"A cosmopolitan atmosphere thanks to the organic shapes created by Ulf Moritz' profiles"*

**Roeselare**  
— BE

***Bardò***

# *Pink Eye*

Antwerpen  
— BE

3 SX155 p. 155



4 F12 p. 140



1 C217 p. 88



2 DX170-2300 p. 105

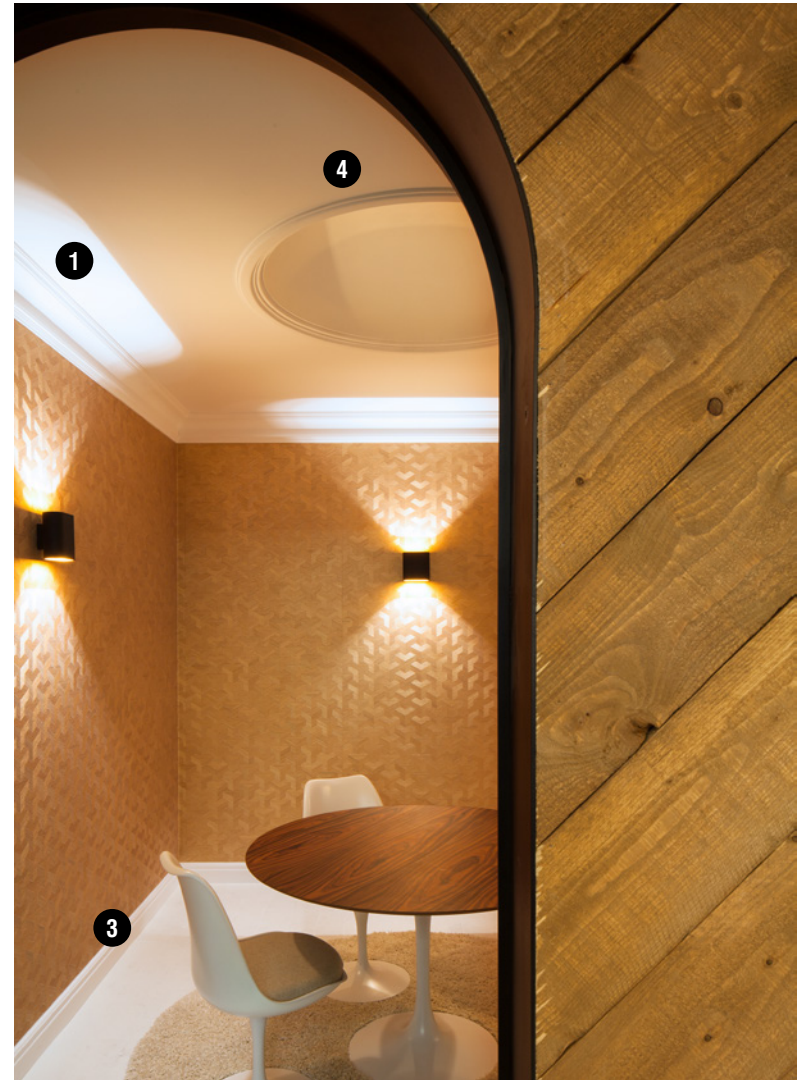

1 C371 SHADE p. 66

designed by Ulf Meitz



2 DX163-2300 p. 115



3 C370 CLOUD

designed by Ulf Meitz



5 P3071 GOLF p. 67

designed by Ulf Meitz



4 SX167 DUNE p. 67

designed by Ulf Meitz

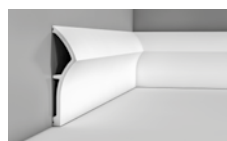

6 R66 p. 138



# Big One

Oostende  
— BE



P PANEL MOULDINGS 100-111



pl

Jeżeli chce się mieć wpływ na świat kreatywnego projektowania wnętrz, należy dawać dobry przykład. W siedzibie głównej ORAC w salonie wystawowym, obszerna kolekcja produktów zajmuje najważniejsze miejsce i jest przedstawiona w zaskakujący sposób.

fr

Pour être une source d'inspiration créative dans l'univers de la décoration d'intérieur, il faut soi-même donner le bon exemple. Dans le show-room du siège d'ORAC, la collection étendue de la marque occupe une place prépondérante, et ce, d'une manière particulièrement étonnante.

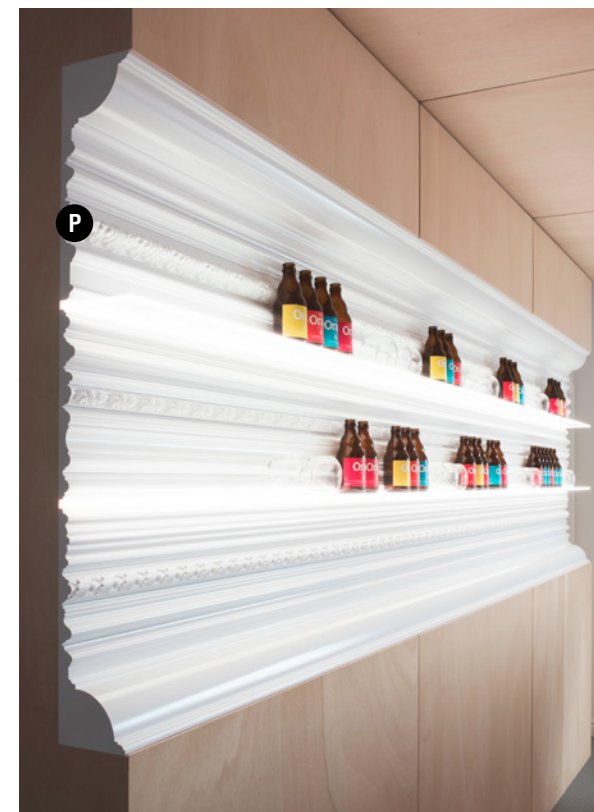

**en**

If you want to inspire creativity in the interior design world, you have to set a good example. In the showroom at the ORAC head office, the extensive collection takes centre stage in a really surprising way.

**ru**

Если вы хотите вдохновлять творчество в мире интерьерного дизайна, вам необходимо подавать хороший пример. В выставочном зале Orac (Остенде) коллекция показана самым удивительным образом.

**ar**

إذا أردت أن تكون مصدر إلهام إبداعي في عالم التصميم الداخلي، يجب أن تكون قدوة حسنة. في صالة عرض مقر أورك، تحتل المجموعة مكانا بارزا بشكل ملفت للنظر.

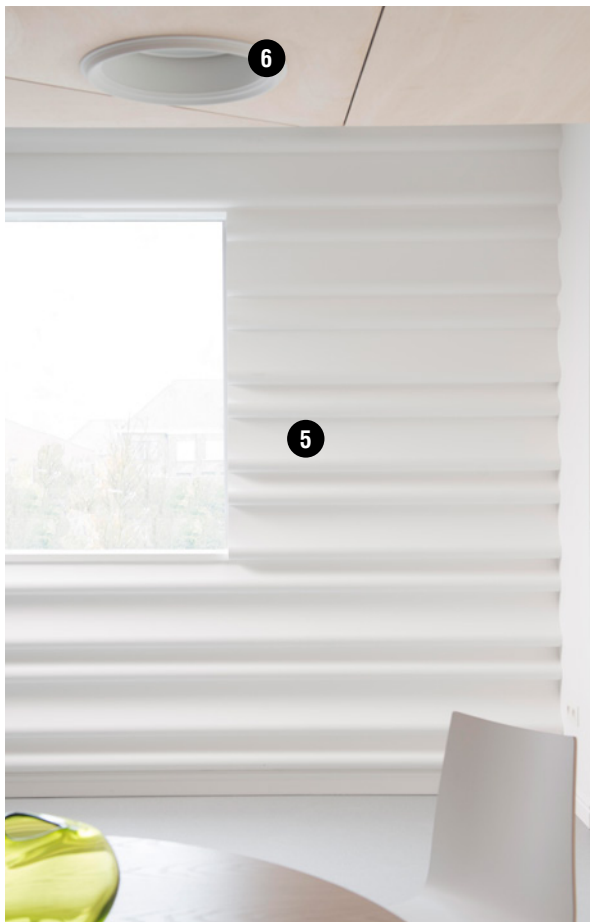

*“Show 'm what you've got: the live interpretation of the ORAC identity”*





*pl*

W Pensjonacie Porters, tradycyjne, przytulne wnętrza są perfekcyjnie zharmonizowane z architekturą budynku. W każdym z pomieszczeń zastosowane kolumny, gzymsy oraz okładziny ścienne zwracają uwagę w sposób niemal teatralny.

*fr*

Dans la maison d'hôtes Porters, l'intérieur chaleureux et intemporel est en parfaite harmonie avec l'architecture du bâtiment. D'une manière théâtrale, les colonnes, corniches et revêtements muraux attirent tous les regards dans chacune des chambres.

# House of Antwerpen — BE Porters

1 K1002+K1152 p. 144

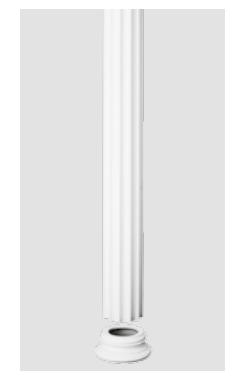

2 C422 p. 89



3 R76 p. 138



2



# Pieter Porters



## en

In Porters Guesthouse, the traditional warm interior harmonises perfectly with the architecture of the building. In every room columns, cornice mouldings and wall coverings draw your attention in an almost theatrical manner.

## ru

В гостевом домике Porters традиционный теплый интерьер идеально сочетается с архитектурой здания. Почти театральным образом в каждой комнате представлены колонны, карнизы и обои.

## ar

في فندق بورتز، دفء الداخل التقليدي يتناغم تماما مع هندسة المبنى. في كل غرفة، تجذب الأعمدة، الكرانيش وأنسجة الجدران الإنتباه بطريقة شبه مسرحية.



**1** C900 *p. 89*



**2** C307 *p. 90*



**3** C338B BA'ROCK *p. 89*



**4** SX118 *p. 116*



**5** P4020 *p. 102*



**6** DX121-2300 *p. 104*



**7** P7030 *p. 104*



**8** P9010 *p. 104*



**9** PX103+PX103A *p. 110*



**10** P3020A+P3020 *p. 109*



**11** K200 *p. 146*



**12** D320 *p. 146*



**13** D401+D402 *p. 132*

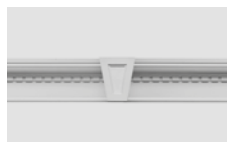

**14** D503+D504+D507 *p. 130*



**15** M9010L *p. 134*



**16** P20 *p. 147*



*Reflecting*  
your  
*Imagination*

ORAC<sup>®</sup>  
DECOR



The image shows a 3D perspective of a wall panel. The panel has a light blue background with several colorful birds in flight. A white, three-dimensional geometric frame, resembling a stylized house or a cube, is mounted on the panel. The birds are painted in various colors: one is yellow and white, another is green and purple, and a third is red and yellow. The lighting creates soft shadows and highlights on the panel's surface.

*Liberté*

Let your Creativity flow

# Product Overview

	<b>CORNICE MOULDINGS</b>	<b>PANEL MOULDINGS</b>	<b>SKIRTING BOARDS</b>	<b>INDIRECT LIGHTING</b>	<b>DECO ELEMENTS</b>
	GZYMSY CORNICHES КАРНИЗЫ كرانش	PROFILE CIMAISES МОЛДИНГИ قوالب للجدران	LISTWY PRZYPODŁOGOWE PLINTHES ПЛИНТУСЫ نعلات	LISTWY OŚWIETLENIOWE ÉCLAIRAGE INDIRECT СКРЫТОЕ ОСВЕЩЕНИЕ إضاءة غير مباشرة	ELEMENTY DEKORACYJNE ÉLÉMENTS DÉCORATIFS ДЕКОРАТИВНЫЕ ЭЛЕМЕНТЫ أصناف للزينة
<b>ULF MORITZ</b>	<b>p.67-70</b>	<b>p.67</b>	<b>p.67</b>	<b>p.66-69</b>	<b>p.71-79</b>
3D DARING DESIGNS	PUROTOUCH <sup>®</sup>	PUROTOUCH <sup>®</sup>	PUROTOUCH <sup>®</sup> DUROPOLYMER <sup>®</sup>	PUROTOUCH <sup>®</sup>	PUROTOUCH <sup>®</sup> DUROPOLYMER <sup>®</sup>
<b>LUXXUS</b>	<b>p.82-91</b>	<b>p.102-105</b>	<b>p.114-117</b>	<b>p.120-125</b>	<b>p.128-148</b>
EXCLUSIVE & STYLISH CONCEPTS	PUROTOUCH <sup>®</sup>	PUROTOUCH <sup>®</sup> DUROPOLYMER <sup>®</sup>	DUROPOLYMER <sup>®</sup>	PUROTOUCH <sup>®</sup>	PUROTOUCH <sup>®</sup> DUROPOLYMER <sup>®</sup>
<b>AXXENT</b>	<b>p.92-96</b>	<b>p.106-108</b>	<b>p.114-117</b>		
HIGH QUALITY INTERIOR SOLUTIONS	DUROPOLYMER <sup>®</sup>	DUROPOLYMER <sup>®</sup>	DUROPOLYMER <sup>®</sup>		
<b>BASIXX</b>	<b>p.97</b>				
BUDGET FRIENDLY DESIGNS	DUROFOAM <sup>®</sup>				

## **Purotouch<sup>®</sup>**

Wysokiej jakości, dużej gęstości, formowany poliuretan.

Un polyuréthane moulé de haute densité.

A moulded quality high-density polyurethane.

Качественный полиуретан высокой плотности

بيوروتاتش<sup>®</sup>: بوليوريثين مقولب عالي الكثافة.

## **Duropolym<sup>®</sup>**

Tłoczony, odporny na uderzenia polimer powstały na bazie polistyrenu o wysokiej gęstości.

Un polymère extrudé résistant aux impacts à base d'un mélange de polystyrènes haute densité.

An extruded and impact-resistant polymer based on a high-density polystyrene.

Экструдированный и ударопрочный полимер, основанный на полистироле высокой плотности

دوروبوليمر<sup>®</sup>: بوليمر مبثوق ومقاوم للصدمات، من مزيج بوليستيرين عالي الكثافة.

## **Durofoam<sup>®</sup>**

Lekki, tłoczony polimer na bazie mieszanki polistyrenów o wysokiej gęstości.

Un polymère léger extrudé à base d'un mélange de polystyrènes de densité moyenne.

An extruded lightweight polymer based on a medium-density polystyrene blend.

Экструдированный легкий полимер, основанный на полистирольной смеси средней плотности

دوروفوم<sup>®</sup>: بوليمر مبثوق وخفيف الوزن، من مزيج بوليستيرين متوسط الكثافة.

## **ADHESIVES AND ACCESSORIES**

KLEJE I AKCESORIA  
COLLES ET ACCESSOIRES  
КЛЕЙ И ИНСТРУМЕНТЫ  
مواد لاصقة ولوازم

**p.148-153**







## pl

Kolekcja Ulf Moritz wprowadza ruch i dynamikę do pomieszczeń. Gama tych wyjątkowych produktów dla ścian i sufitów, w niektórych wzorach ze zintegrowanym oświetleniem, tworzy niespotykane efekty 3D. Okazała, imponująca i równocześnie elegancka kolekcja.

## fr

Ulf Moritz : un nom de caractère pour votre intérieur. Au mur ou au plafond, avec un éclairage intégré ou non, les éléments design de la collection assurent un vécu 3D incomparable. Une combinaison de puissance, de grandeur et d'élégance.

## en

Ulf Moritz brings movement and dynamics to your interior. The collection of design elements for walls and ceilings, with or without integrated lighting, creates an unparalleled 3D effect. Powerful, imposing and elegant at the same time.

## ru

Ulf Moritz приносит движение и динамику в ваш интерьер. Коллекция дизайнерских элементов для стен и потолков, с или без скрытого освещения, которая создает беспрецедентный 3D эффект. Яркий, внушительный и одновременно элегантный.

## ar

أصناف المصمم أولف موريتز تضيفي حركة وديناميكية على التصميم الداخلي. المجموعة المصممة للجدران والسقوف، مع أو دون إضاءة مدمجة، تخلق تأثير ثلاثي الأبعاد لا يضاهي. مزيج من القوة، الفخامة والأناقة.

# Ulf Moritz Collection

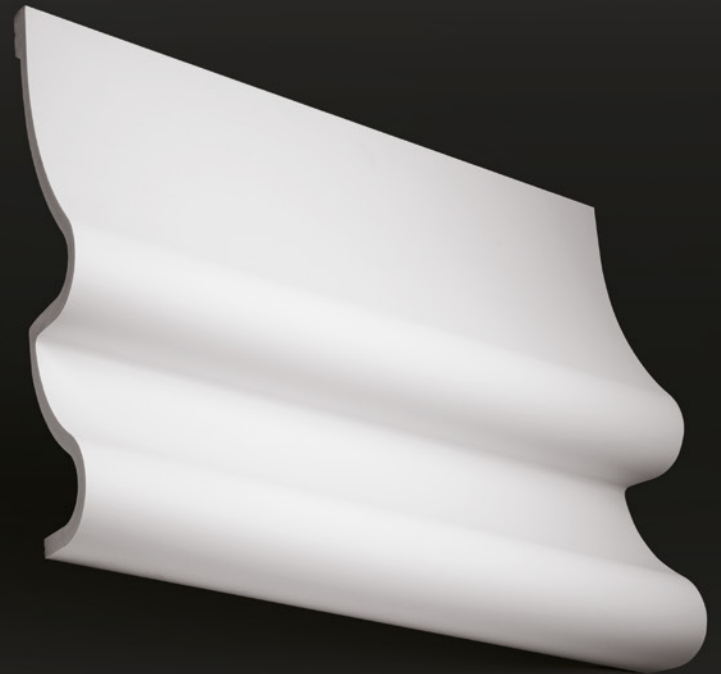

## Ulf Moritz Collection



❶ **C374 ANTONIO** p. 68

❷ **C371 SHADE** p. 66

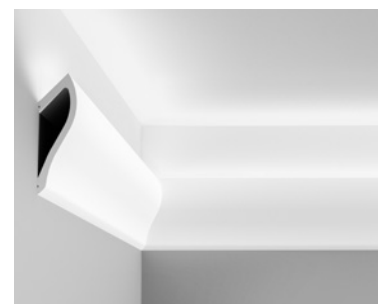

### C371 SHADE

200 x 18,5 x 5,8 cm  
Purotouch<sup>®</sup>

ULF MORITZ

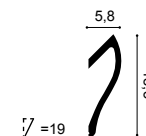

### C372 FLUXUS

200 x 28 x 7 cm  
Purotouch<sup>®</sup>

ULF MORITZ

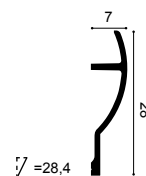



**C370 CLOUD**

ULF MORITZ

200 x 20 x 16 cm  
Purotouch<sup>®</sup>

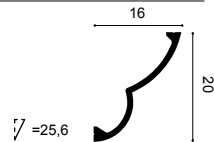

**P3071 GOLF**

200 x 37,2 x 7,6 cm  
Purotouch<sup>®</sup>

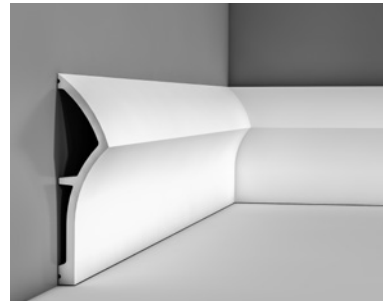

**SX167 DUNE**

ULF MORITZ

200 x 17,3 x 4,3 cm  
Duropolymer<sup>®</sup>

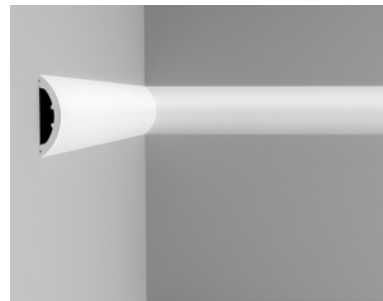
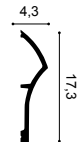

**P3070 RADIUS**

ULF MORITZ

200 x 12,5 x 3,2 cm  
Purotouch<sup>®</sup>

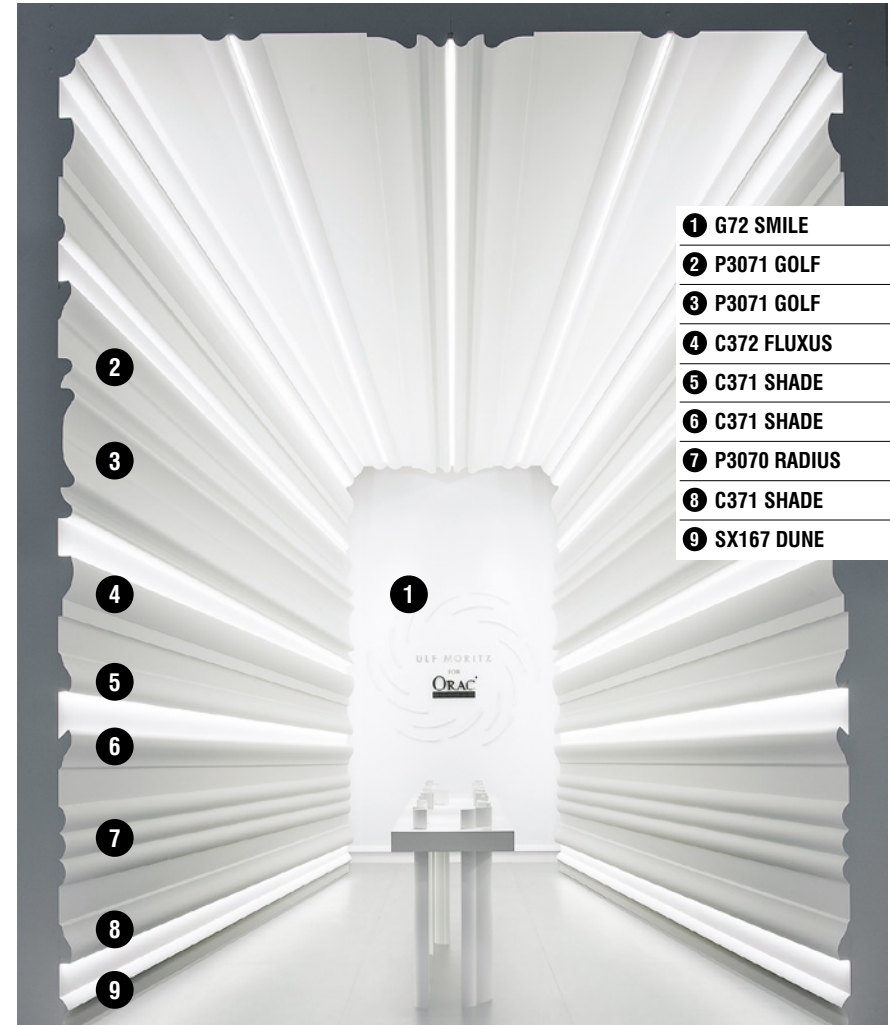

- |   |              |       |
|---|--------------|-------|
| 1 | G72 SMILE    | p. 72 |
| 2 | P3071 GOLF   | p. 67 |
| 3 | P3071 GOLF   | p. 67 |
| 4 | C372 FLUXUS  | p. 66 |
| 5 | C371 SHADE   | p. 66 |
| 6 | C371 SHADE   | p. 66 |
| 7 | P3070 RADIUS | p. 67 |
| 8 | C371 SHADE   | p. 66 |
| 9 | SX167 DUNE   | p. 67 |

## Ulf Moritz Collection

1 C374 ANTONIO p. 68

2 C991 p. 70



**C373 | C373F ANTONIO**

200 x 8 x 5 cm  
Purotouch<sup>®</sup>

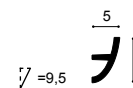

ULF MORITZ

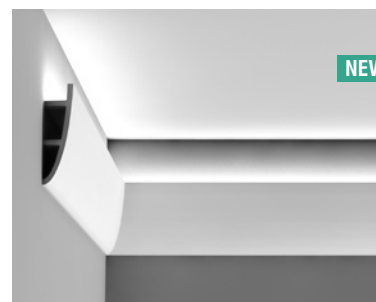

**C374 | C374F ANTONIO**

200 x 18 x 5 cm  
Purotouch<sup>®</sup>

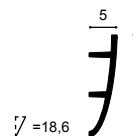

ULF MORITZ

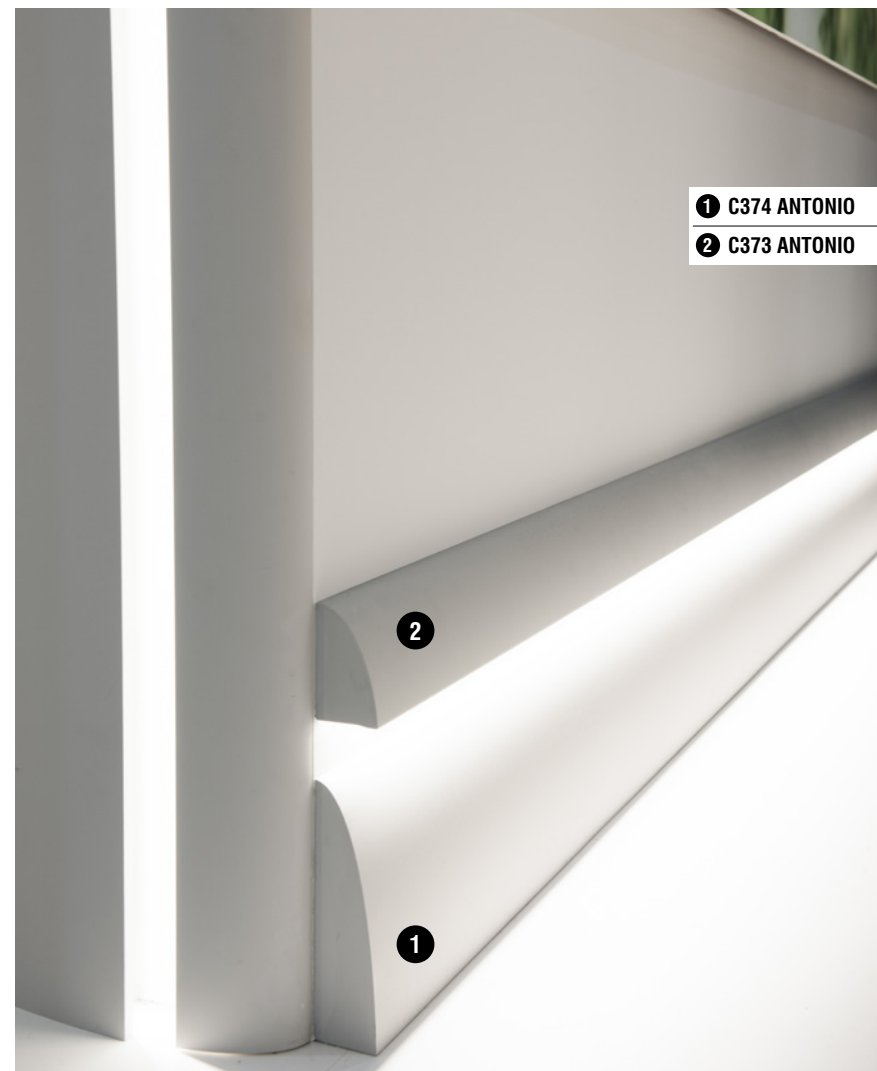

# Ulf Moritz Collection



## C991 CURTAIN PROFILE

200 x 11 x 14 cm  
Purotouch<sup>®</sup>

ULF MORITZ

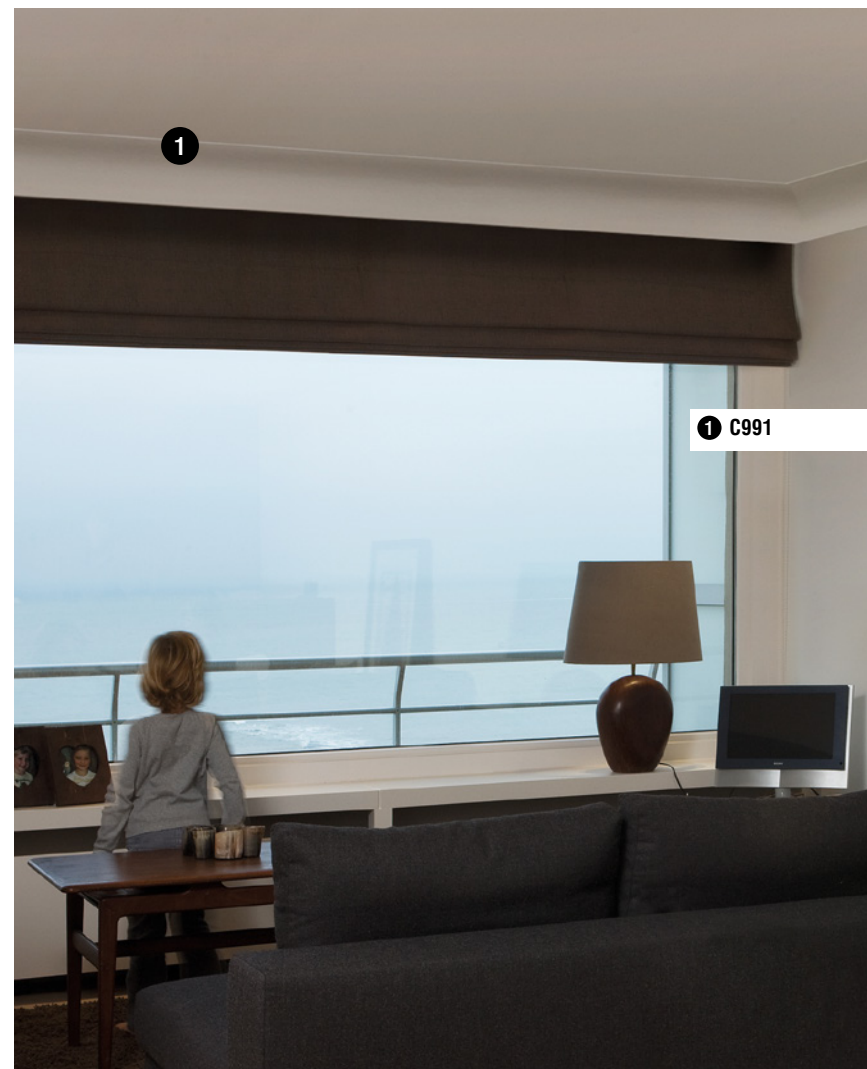
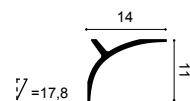

p. 70

# Ulf Moritz Collection



**G71 SCALA**

ULF MORITZ

42,2 x 35 x 1,5 cm  
Purotouch<sup>®</sup>

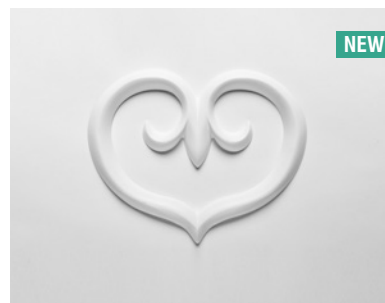
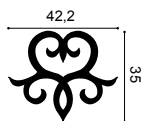

NEW

**G75 SCALA**

ULF MORITZ

27 x 21 x 1,4 cm  
Purotouch<sup>®</sup>

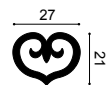

NEW

**G76 SCALA**

ULF MORITZ

8 x 17,8 x 1,5 cm  
Purotouch<sup>®</sup>

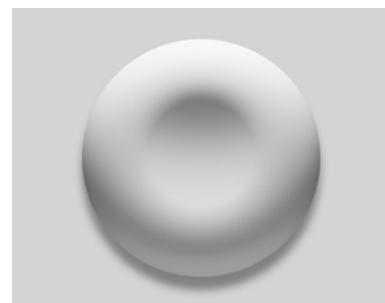

**R70 FOCUS**

ULF MORITZ

Ø 60 x 7,7 cm  
Purotouch<sup>®</sup>

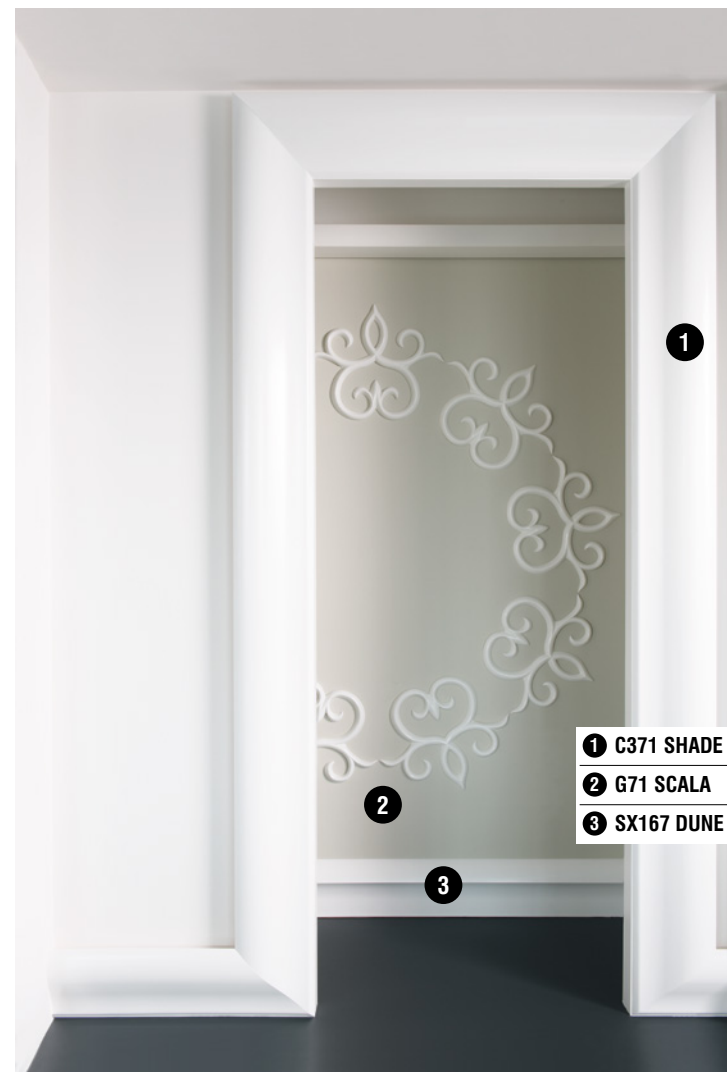
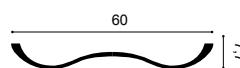

- 1** C371 SHADE p. 66
- 2** G71 SCALA p. 71
- 3** SX167 DUNE p. 67



# Ulf Moritz Collection



**G70 FOLIO** ULF MORITZ  
20 x 9 x 2,7 cm  
Duropolymer<sup>®</sup>

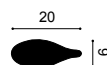

**G72 SMILE** ULF MORITZ  
42,5 x 6,8 x 1 cm  
Duropolymer<sup>®</sup>

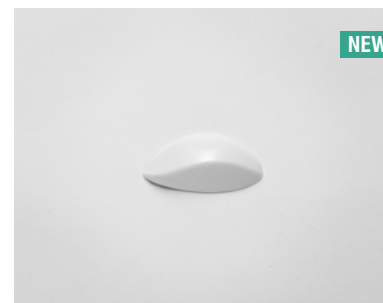
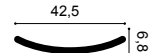

**G78 LILY** ULF MORITZ  
8,8 x 4,4 x 1,9 cm  
Duropolymer<sup>®</sup>



**G77 LILY** ULF MORITZ  
19,4 x 8,8 x 1,8 cm  
Duropolymer<sup>®</sup>



**G73L CURL MINI** ULF MORITZ  
20,1 x 18,1 x 1 cm  
Purotouch<sup>®</sup>

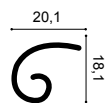

**G73R CURL MINI** ULF MORITZ  
20,1 x 18,1 x 1 cm  
Purotouch<sup>®</sup>

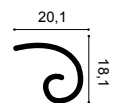

**G74L CURL MAXI** ULF MORITZ  
25,4 x 24,4 x 1,1 cm  
Purotouch<sup>®</sup>

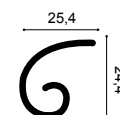

**G74R CURL MAXI** ULF MORITZ  
25,4 x 24,4 x 1,1 cm  
Purotouch<sup>®</sup>

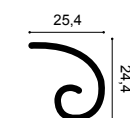



- |    |               |       |
|----|---------------|-------|
| 1  | G77 LILY      | p. 72 |
| 2  | P3071 GOLF    | p. 67 |
| 3  | C372 FLUXUS   | p. 66 |
| 4  | C373 ANTONIO  | p. 68 |
| 5  | C374 ANTONIO  | p. 68 |
| 6  | G74 CURL MAXI | p. 72 |
| 7  | G72 SMILE     | p. 72 |
| 8  | G73 CURL MINI | p. 72 |
| 9  | SX167 DUNE    | p. 67 |
| 10 | C371 SHADE    | p. 66 |

Ulf Moritz Collection

ŚCIANA / MUR / WALL / CTEHA / جدار

---

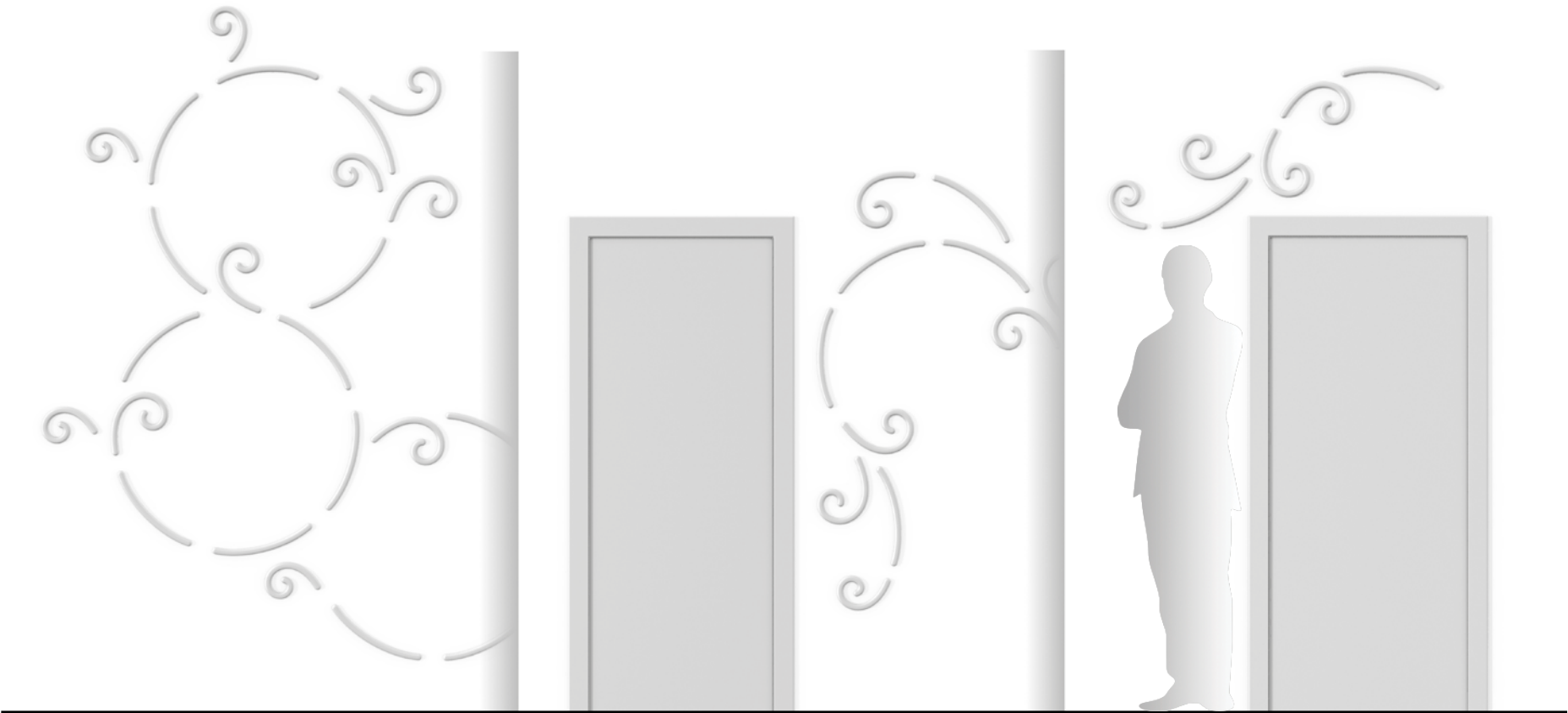

# Ulf Moritz Collection

ŚCIANA / MUR / WALL / CTEHA / جدار

---

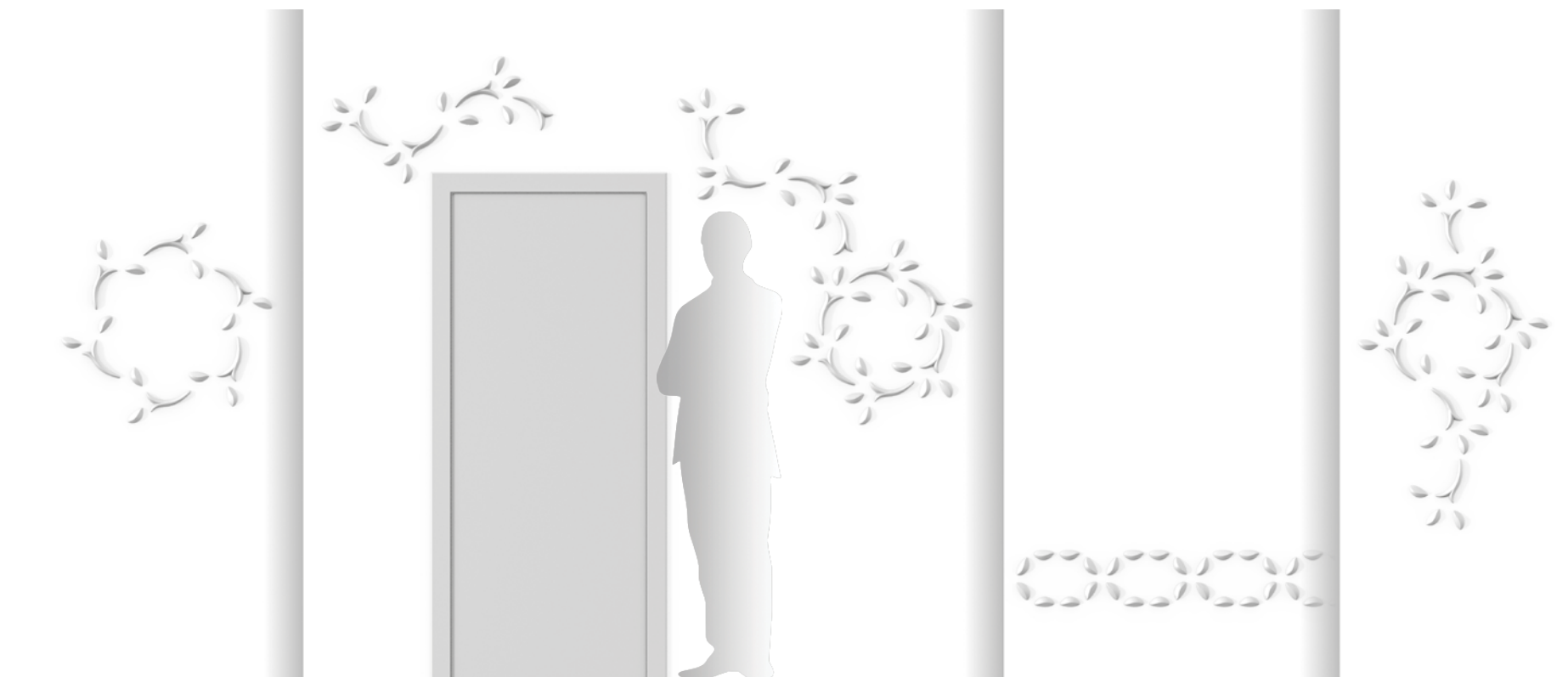

Ulf Moritz Collection

ŚCIANA / MUR / WALL / CTEHA / جدار

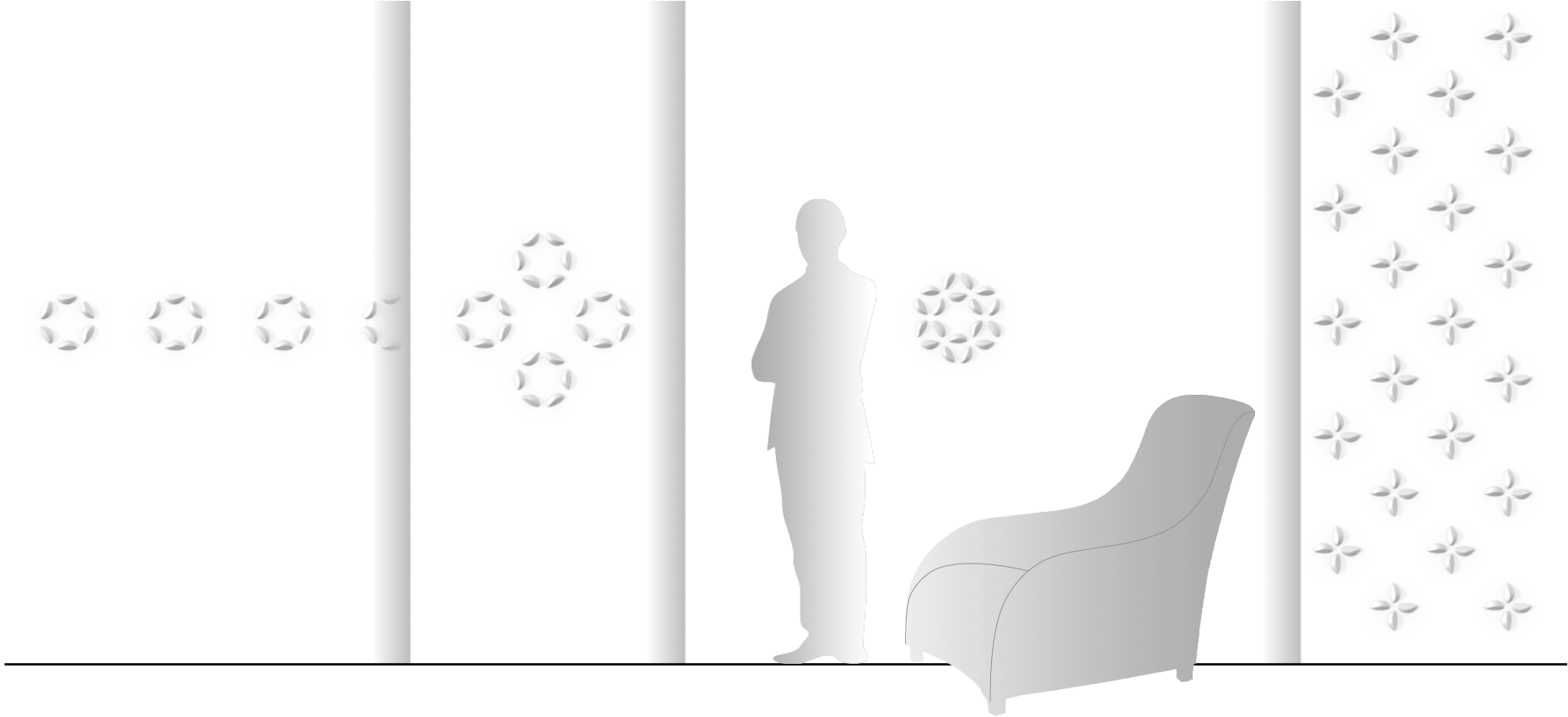

# Ulf Moritz Collection

ŚCIANA / MUR / WALL / CTEHA / جدار

---

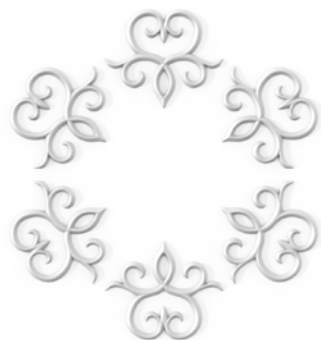

# Ulf Moritz Collection

SUFIT / PLAFOND / CEILING / ПОТОЛОК / سقف

---

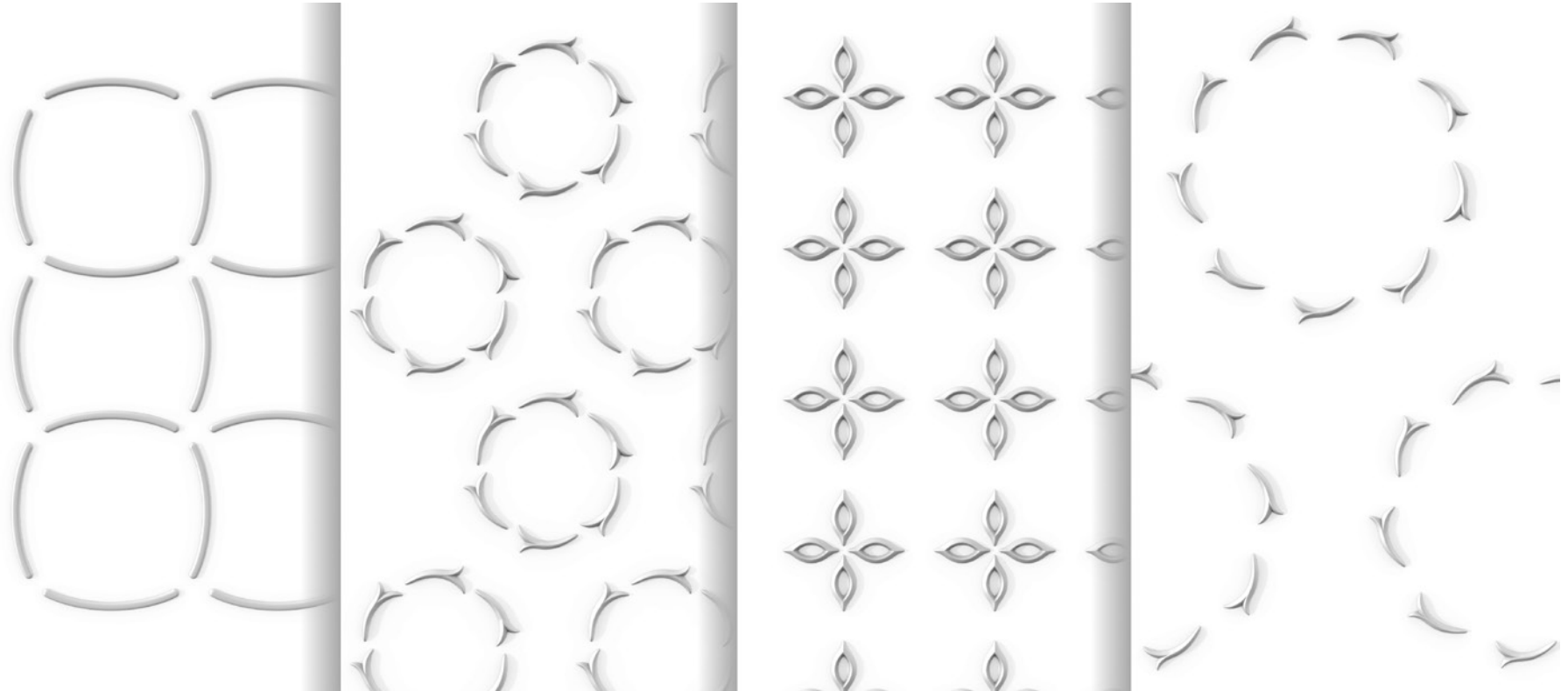

# Ulf Moritz Collection

SUFIT / PLAFOND / CEILING / ПОТОЛОК / سقف

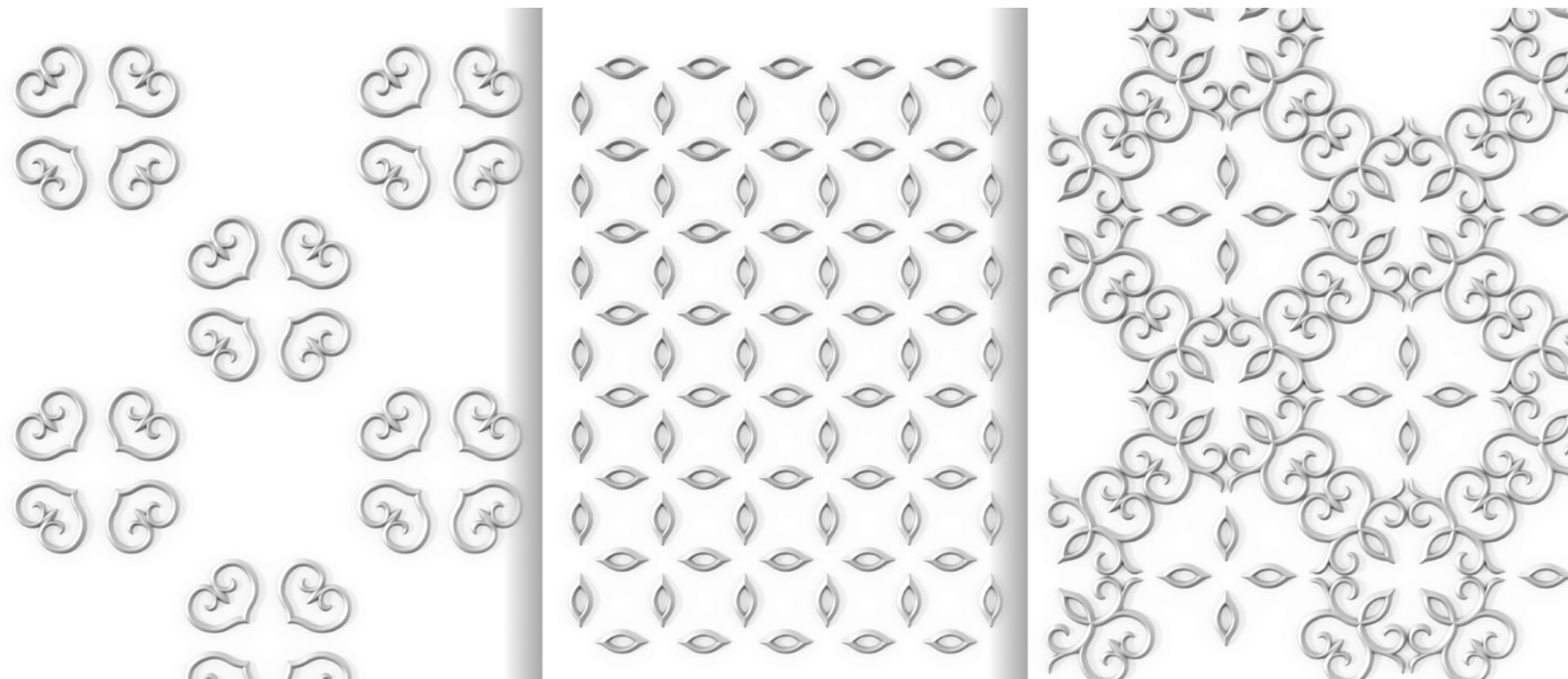





## pl

Gzymsy tworzą wizualnie atrakcyjne połączenie pomiędzy ścianami i sufitem. Od gładkich do barokowych, od dekoracyjnych do funkcjonalnych – oferujemy wysokiej jakości rozwiązania na każdą kieszeń. Gzymsy Orac są łatwe do instalacji, a wiele naszych wzorów jest dostępnych w wersji elastycznej.

## fr

Une moulure ajoute un effet visuellement intéressant à la transition entre mur et plafond. Quel que soit votre budget, nous vous proposons une solution de qualité : du style minimaliste au baroque, de l'élément décoratif au fonctionnel. Les profils sont faciles à poser, et un grand nombre de produits sont également disponibles en version flexible.

## en

A cornice creates a visually attractive transition from wall to ceiling. From sleek to baroque, from decorative to functional – we offer a quality solution for every budget. The profiles are easy to install, and a large number of designs are available in flexible versions.

## ru

Карниз создает визуально привлекательный переход от стены к потолку. От гладких профилей до Барокко, от декоративных до функциональных - мы предлагаем качественное решение на каждый бюджет. Профили легко монтировать. Большое количество дизайнов представлены также в гибком виде.

## ar

كورنيش تخلق إنتقال جذاب بين الحائط والسقف. من التصميم الأنيق إلى الباروك، من الزيني إلى العملي، نحن نقدم حلول عالية الجودة لكل الميزانيات. القوالب سهلة التركيب، وعدد كبير منها متوفر أيضا بصيغة مرنة.

Gzysy  
Corniches  
Cornice Mouldings  
Карнизы  
كرانش





**C250 | C250F**

LUXXUS

200 x 1,6 x 1,6 cm  
Purotouch®

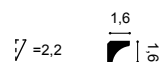

**C360**

LUXXUS

200 x 2,1 x 6 cm  
Purotouch®  
Designed by  
Jacques Vergracht

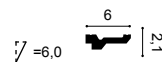

**C230 | C230F**

LUXXUS

200 x 2,9 x 2,9 cm  
Purotouch®

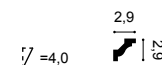

**C356**

LUXXUS

200 x 2 x 10 cm  
Purotouch®  
Designed by  
Jacques Vergracht

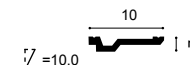

**C353**

LUXXUS

200 x 3 x 16,5 cm  
Purotouch®  
Designed by  
Jacques Vergracht

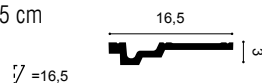

**C355**

LUXXUS

200 x 3,5 x 11,1 cm  
Purotouch®  
Designed by  
Jacques Vergracht

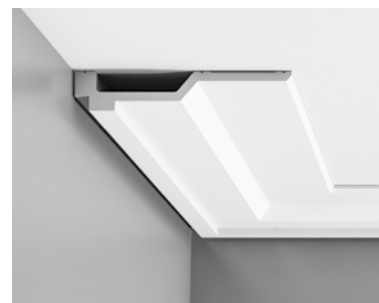
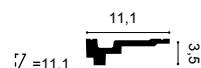

**C354**

LUXXUS

200 x 4 x 21,5 cm  
Purotouch®  
Designed by  
Jacques Vergracht

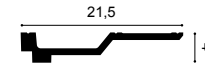

**C260 | C260F**

LUXXUS

200 x 4,1 x 4,8 cm  
Purotouch®

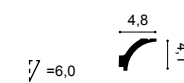



**C305** LUXXUS

200 x 4,7 x 15,5 cm  
Purotouch<sup>®</sup>

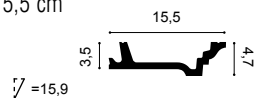

**C305 + C213** LUXXUS

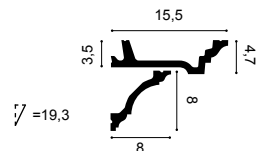

**C305 + C211** LUXXUS

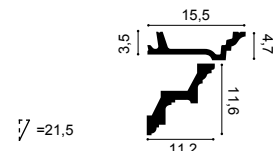

**C215 | C215F** LUXXUS

200 x 4,7 x 4,7 cm  
Purotouch<sup>®</sup>

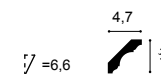

**C322 | C322F** LUXXUS

200 x 5 x 4,2 cm  
Purotouch<sup>®</sup>

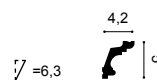

**C602 | C602F** LUXXUS

200 x 5,3 x 5 cm  
Purotouch<sup>®</sup>

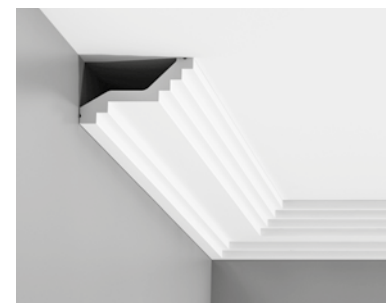
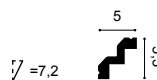

**C400** LUXXUS

200 x 6 x 10 cm  
Purotouch<sup>®</sup>

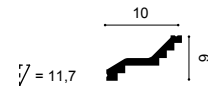

**C331 | C331F** LUXXUS

200 x 6,4 x 13,5 cm  
Purotouch<sup>®</sup>

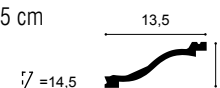



**C200 | C200F** LUXXUS

200 x 6,5 x 5,7 cm  
Purotouch<sup>®</sup>

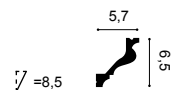

**C214 | C214F** LUXXUS

200 x 6,6 x 3,1 cm  
Purotouch<sup>®</sup>

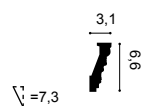

**C212 | C212F** LUXXUS

200 x 7,3 x 4,5 cm  
Purotouch<sup>®</sup>

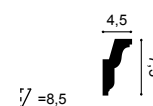

**C220 | C220F** LUXXUS

200 x 7,6 x 11,6 cm  
Purotouch<sup>®</sup>

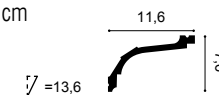

**C213 | C213F** LUXXUS

200 x 8 x 8 cm  
Purotouch<sup>®</sup>

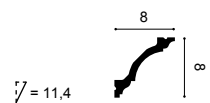

**C240 | C240F** LUXXUS

200 x 8 x 8 cm  
Purotouch<sup>®</sup>

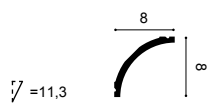

**C341 | C341F HERITAGE M** LUXXUS

200 x 8,8 x 12,2 cm  
Purotouch<sup>®</sup>





**C321 | C321F**

LUXXUS

200 x 9,9 x 5 cm  
Purotouch<sup>®</sup>

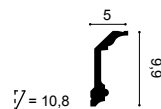

**C902 | C902F**

LUXXUS

200 x 10,3 x 10,3 cm  
Purotouch<sup>®</sup>

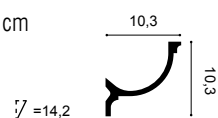

**C217 | C217F**

LUXXUS

200 x 10,3 x 15,6 cm  
Purotouch<sup>®</sup>

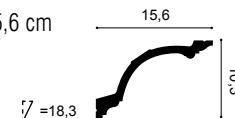

**C402 | C402F**

LUXXUS

200 x 10,7 x 9,4 cm  
Purotouch<sup>®</sup>

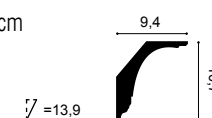

**C332**

LUXXUS

200 x 11,4 x 23 cm  
Purotouch<sup>®</sup>

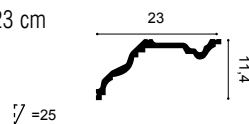

**C201 | C201F**

LUXXUS

200 x 11,6 x 4,8 cm  
Purotouch<sup>®</sup>

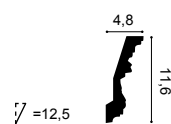

**C211 | C211F**

LUXXUS

200 x 11,6 x 11,2 cm  
Purotouch<sup>®</sup>

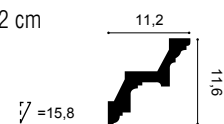

**C216 | C216F**

LUXXUS

200 x 11,6 x 13,3 cm  
Purotouch<sup>®</sup>

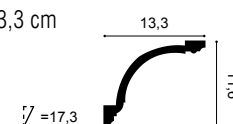



**C304 | C304F**

LUXXUS

200 x 12,2 x 7,2 cm  
Purotouch<sup>®</sup>



**C333 | C333F**

LUXXUS

200 x 12,2 x 11,1 cm  
Purotouch<sup>®</sup>

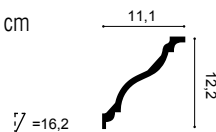

**C302 | C302F**

LUXXUS

200 x 12,8 x 8,5 cm  
Purotouch<sup>®</sup>

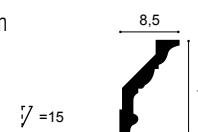

**C340**

LUXXUS

200 x 13,5 x 25,6 cm  
Purotouch<sup>®</sup>

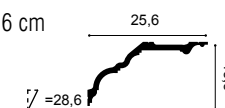

**C991 CURTAIN PROFILE**

200 x 11 x 14 cm  
Purotouch<sup>®</sup>  
Designed by  
Ulf Moritz

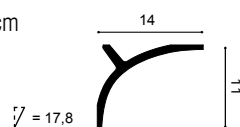

**C991**



**C991 + P9900**

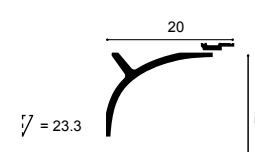

**C991 + 2x P9900**

ULF MORITZ

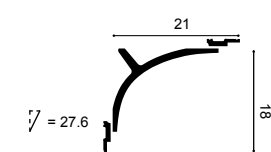



**C342 HERITAGE L**

LUXXUS

200 x 14 x 19 cm  
Purotouch<sup>®</sup>

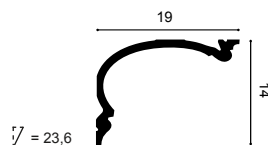

**C339 | C339F**

LUXXUS

200 x 14,1 x 6,4 cm  
Purotouch<sup>®</sup>

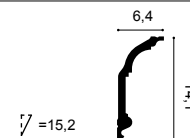

**C303 | C303F**

LUXXUS

200 x 14,4 x 6,5 cm  
Purotouch<sup>®</sup>

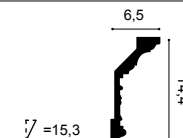

**C991**

200 x 14 x 11 cm  
Purotouch<sup>®</sup>  
Designed by  
Ulfi Moritz

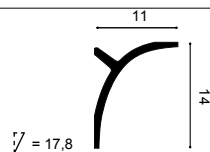

**C991 + P9900**

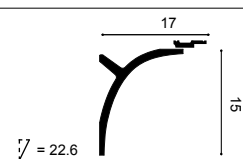

**C991 + 2x P9900**

ULF MORITZ

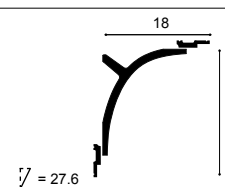

**C218 | C218F**

LUXXUS

200 x 15 x 12 cm  
Purotouch<sup>®</sup>

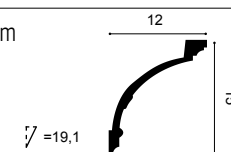





**C334 | C334F**

LUXXUS

200 x 15 x 19,6 cm  
Purotouch<sup>®</sup>

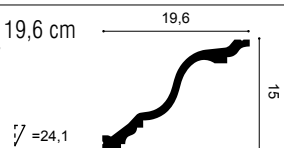

**C901 | C901F**

LUXXUS

200 x 14,8 x 12,4 cm  
Purotouch<sup>®</sup>



**C217 | C217F**

LUXXUS

200 x 15,6 x 10,3 cm  
Purotouch<sup>®</sup>

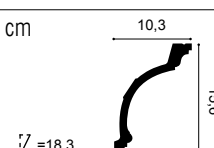

**C300**

LUXXUS

200 x 16,5 x 13 cm  
Purotouch<sup>®</sup>

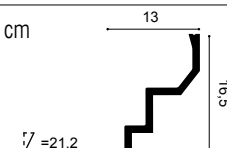

**C990 INFINITY**

200 x 15,9 x 21,6 cm  
Purotouch<sup>®</sup>  
Designed by  
Xavier Donck



**C990 + P9900**

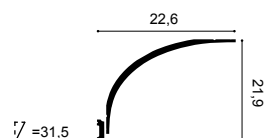

**C990 + 2x P9900**

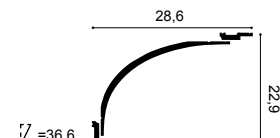

**C990 + P9901**

LUXXUS

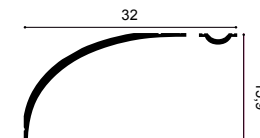



**C900** LUXXUS

200 x 17,1 x 14,6 cm  
Purotouch<sup>®</sup>

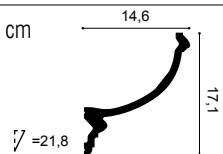

**C422** LUXXUS

200 x 16,4 x 19,4 cm  
Purotouch<sup>®</sup>

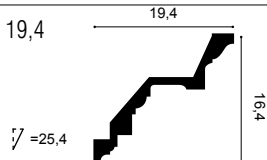

**C301 | C301F** LUXXUS

200 x 17 x 14,4 cm  
Purotouch<sup>®</sup>

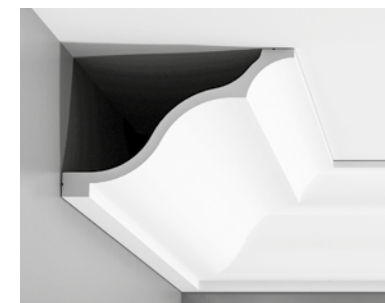
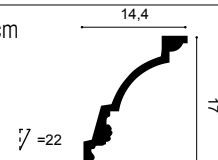

**C337** LUXXUS

200 x 17,2 x 25,6 cm  
Purotouch<sup>®</sup>

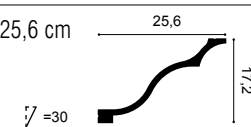

**C219** LUXXUS

200 x 17,6 x 13 cm  
Purotouch<sup>®</sup>

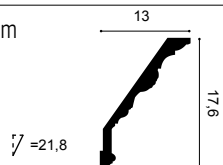

**C338** LUXXUS

200 x 18,4 x 18,4 cm  
Purotouch<sup>®</sup>

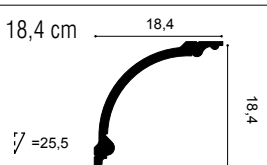

**C338A BA'ROCK** LUXXUS

200 x 18,4 x 18,4 cm  
Purotouch<sup>®</sup>

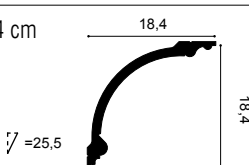

**C338B BA'ROCK** LUXXUS

200 x 18,4 x 18,4 cm  
Purotouch<sup>®</sup>

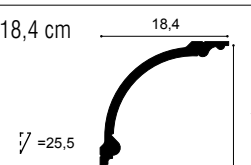



**C343 HERITAGE XL** LUXXUS

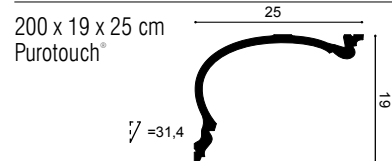

**C990 INFINITY**

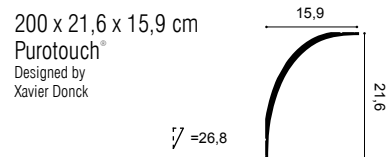

**C307** LUXXUS

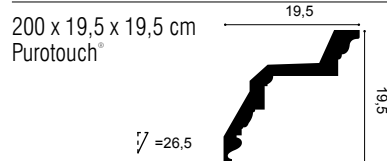

**C990 + P9900**

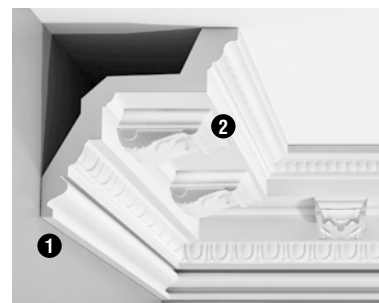
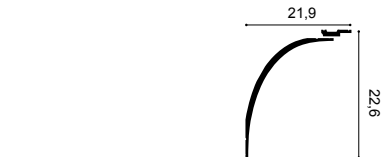

**1 C307 + C307A 2** LUXXUS

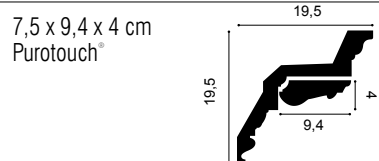

**C990 + 2x P9900**

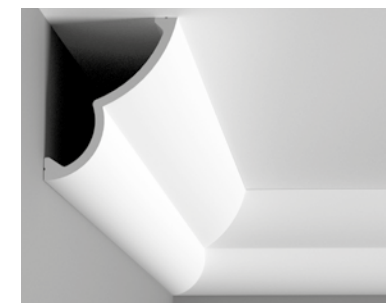
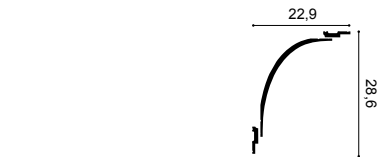

**C370 CLOUD** ULF MORITZ

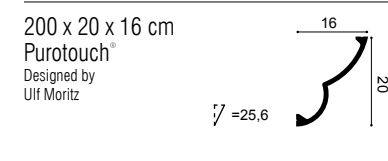

**C990 + P9901** LUXXUS

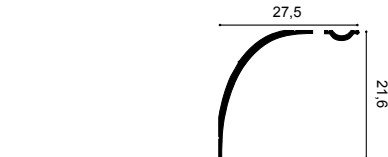

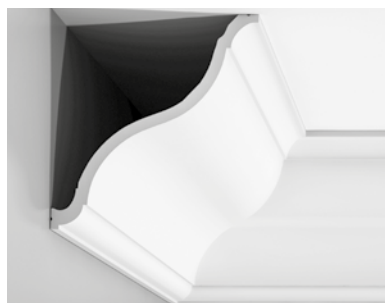

**C335** LUXXUS

200 x 20,2 x 22,2 cm  
Purotouch<sup>®</sup>  
Designed by  
Xavier Donck

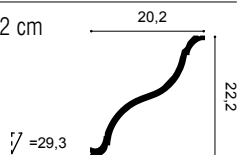

**C340** LUXXUS

200 x 25,6 x 13,5 cm  
Purotouch<sup>®</sup>

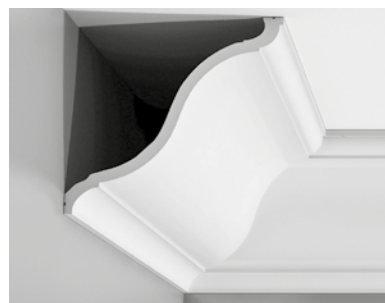
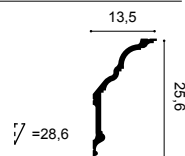

**C335** LUXXUS

200 x 22,2 x 20 cm  
Purotouch<sup>®</sup>  
Designed by  
Xavier Donck

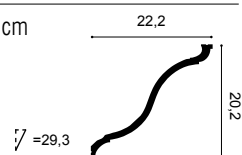

**C336** LUXXUS

200 x 27,1 x 26,6 cm  
Purotouch<sup>®</sup>

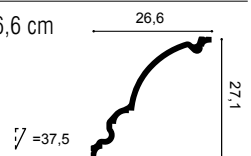

**C332** LUXXUS

200 x 23 x 11,4 cm  
Purotouch<sup>®</sup>

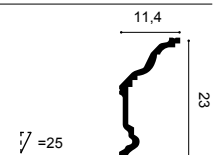

**C344 HERITAGE XXL** LUXXUS

200 x 27,3 x 35 cm  
Purotouch<sup>®</sup>

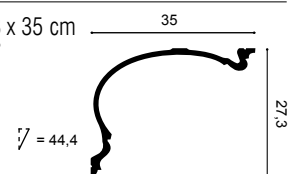

**C308 | C308F** LUXXUS

200 x 24,8 x 6,3 cm  
Purotouch<sup>®</sup>

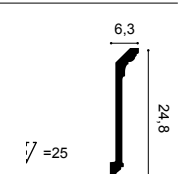

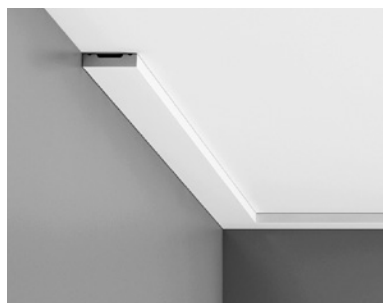

**DX162-2300**

AXXENT

230 x 1 x 4 cm  
Duopolymer<sup>®</sup>



**DX159-2300**

AXXENT

230 x 1,2 x 6 cm  
Duopolymer<sup>®</sup>



**CX160**

AXXENT

200 x 1,3 x 3,9 cm  
Duopolymer<sup>®</sup>



**DX157-2300 | DX157F**

AXXENT

230 x 6,6 x 1,3 cm (DX157-2300)  
200 x 6,6 x 1,3 cm (DX157F)  
Duopolymer<sup>®</sup>



**CX161**

AXXENT

200 x 1,3 x 6,9 cm  
Duopolymer<sup>®</sup>



**DX163-2300**

AXXENT

230 x 1,3 x 10,2 cm  
Duopolymer<sup>®</sup>

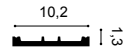

**DX168-2300**

AXXENT

230 x 1,4 x 15,1 cm  
Duopolymer<sup>®</sup>

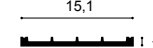

**CX132 | CX132F**

AXXENT

200 x 2 x 2 cm  
Duopolymer<sup>®</sup>

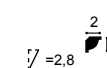



**CX133**

AXXENT

200 x 2 x 2 cm  
Duropolymer<sup>®</sup>

$\nabla = 2,7$  



**CX111**

AXXENT

200 x 2,6 x 1,5 cm  
Duropolymer<sup>®</sup>

$\nabla = 2,8$  



**PX164**

AXXENT

200 x 2,4 x 3 cm  
Duropolymer<sup>®</sup>

$\nabla = 3,9$  



**CX115**

AXXENT

200 x 3 x 2,9 cm  
Duropolymer<sup>®</sup>

$\nabla = 3,9$  



**CX154**

AXXENT

200 x 3 x 3 cm  
Duropolymer<sup>®</sup>

$\nabla = 4,1$  



**CX148 | CX148F**

AXXENT

200 x 4,3 x 2,9 cm  
Duropolymer<sup>®</sup>

$\nabla = 5,1$  



**CX149**

AXXENT

200 x 4,3 x 2,9 cm  
Duropolymer<sup>®</sup>

$\nabla = 5,1$  



**CX150**

AXXENT

200 x 4,3 x 2,9 cm  
Duropolymer<sup>®</sup>

$\nabla = 5,1$  

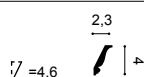

**CX151** AXSENT  
200 x 4,0 x 2,3 cm  
Duopolymer<sup>®</sup>  
∠ = 4,6 

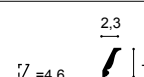

**CX152** AXSENT  
200 x 4,0 x 2,3 cm  
Duopolymer<sup>®</sup>  
∠ = 4,6 

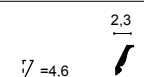

**CX153** AXSENT  
200 x 4,0 x 2,3 cm  
Duopolymer<sup>®</sup>  
∠ = 4,6 

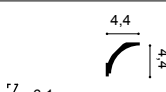

**CX109 | CX109F** AXSENT  
200 x 4,4 x 4,4 cm  
Duopolymer<sup>®</sup>  
∠ = 6,1 

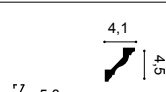

**CX110 | CX110F** AXSENT  
200 x 4,5 x 4,1 cm  
Duopolymer<sup>®</sup>  
∠ = 5,8 

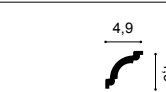

**CX124 | CX124F** AXSENT  
200 x 4,9 x 4,9 cm  
Duopolymer<sup>®</sup>  
∠ = 6,8 



**CX112** AXSENT  
200 x 5,4 x 3,8 cm  
Duopolymer<sup>®</sup>  
∠ = 6,6 

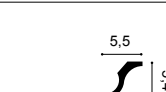

**CX108** AXSENT  
200 x 5,4 x 5,5 cm  
Duopolymer<sup>®</sup>  
∠ = 7,6 



**CX141** AXXENT  
200 x 5,9 x 3,1 cm  
Duropolymer<sup>®</sup>  
∠ = 6,7



**CX142** AXXENT  
200 x 5,9 x 3,1 cm  
Duropolymer<sup>®</sup>  
∠ = 6,7



**CX143** AXXENT  
200 x 5,9 x 3,1 cm  
Duropolymer<sup>®</sup>  
∠ = 6,7



**CX100 | CX100F** AXXENT  
200 x 6,9 x 7,1 cm  
Duropolymer<sup>®</sup>  
∠ = 9,7



**CX101** AXXENT  
200 x 6,9 x 7,1 cm  
Duropolymer<sup>®</sup>  
∠ = 9,7



**CX136** AXXENT  
200 x 6,9 x 7,1 cm  
Duropolymer<sup>®</sup>  
∠ = 9,7



**CX123** AXXENT  
200 x 8 x 8 cm  
Duropolymer<sup>®</sup>  
∠ = 11



**CX126** AXXENT  
200 x 8,7 x 8,7 cm  
Duropolymer<sup>®</sup>  
∠ = 12,2





**CX127 | CX127F**

AXXENT

200 x 9,4 x 9,4 cm  
Duropolymer<sup>®</sup>

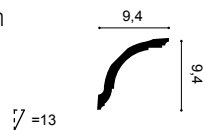

**CX128**

AXXENT

200 x 9,4 x 9,4 cm  
Duropolymer<sup>®</sup>

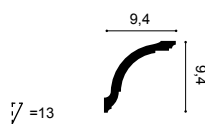

**CX106**

AXXENT

200 x 11,8 x 11,7 cm  
Duropolymer<sup>®</sup>

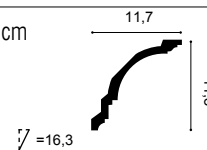

**CX129**

AXXENT

200 x 9,4 x 9,4 cm  
Duropolymer<sup>®</sup>

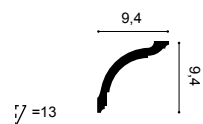

**CX107**

AXXENT

200 x 11,8 x 11,7 cm  
Duropolymer<sup>®</sup>

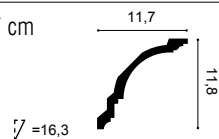



**CB500** BASIXX  
200 x 2,5 x 1,8 cm  
Durofoam<sup>®</sup>  
1,8  
2,5  
∠ = 3



**CB530** BASIXX  
200 x 2,7 x 1,5 cm  
Durofoam<sup>®</sup>  
1,5  
2,7  
∠ = 3,2



**CB520** BASIXX  
200 x 3,5 x 3,5 cm  
Durofoam<sup>®</sup>  
3,5  
3,5  
∠ = 5



**CB510** BASIXX  
200 x 4 x 4 cm  
Durofoam<sup>®</sup>  
4  
4  
∠ = 5,6



**CB501** BASIXX  
200 x 4,1 x 3,5 cm  
Durofoam<sup>®</sup>  
3,5  
4,1  
∠ = 5,3



**CB531** BASIXX  
200 x 4,2 x 2,6 cm  
Durofoam<sup>®</sup>  
2,6  
4,2  
∠ = 5,2



**CB521** BASIXX  
200 x 5 x 5 cm  
Durofoam<sup>®</sup>  
5  
5  
∠ = 7,1



**CB523** BASIXX  
200 x 5,9 x 4,4 cm  
Durofoam<sup>®</sup>  
4,4  
5,9  
∠ = 7,2



**CB502** BASIXX  
200 x 5,9 x 4,9 cm  
Durofoam<sup>®</sup>  
4,9  
5,9  
∠ = 7,8

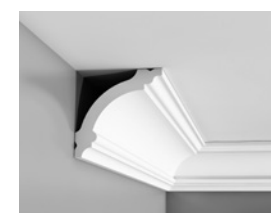

**CB511** BASIXX  
200 x 6,7 x 6,7 cm  
Durofoam<sup>®</sup>  
6,7  
6,7  
∠ = 9,8



**CB522** BASIXX  
200 x 6,7 x 6,7 cm  
Durofoam<sup>®</sup>  
6,7  
6,7  
∠ = 9,7

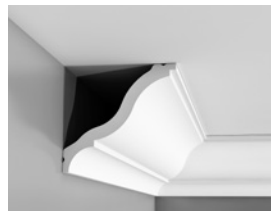

**CB503** BASIXX  
200 x 8,2 x 9,2 cm  
Durofoam<sup>®</sup>  
9,2  
8,2  
∠ = 12,3



**CB512** BASIXX  
200 x 10 x 10 cm  
Durofoam<sup>®</sup>  
10  
10  
∠ = 13,8



**PB513** BASIXX  
200 x 3,4 x 1,5 cm  
Durofoam<sup>®</sup>  
3,4  
1,5  
∠ = 1

# ORAC FLEX (REF + F)

Gzysmy / Corniches / Cornice Mouldings / Карнизы / کرانیچ

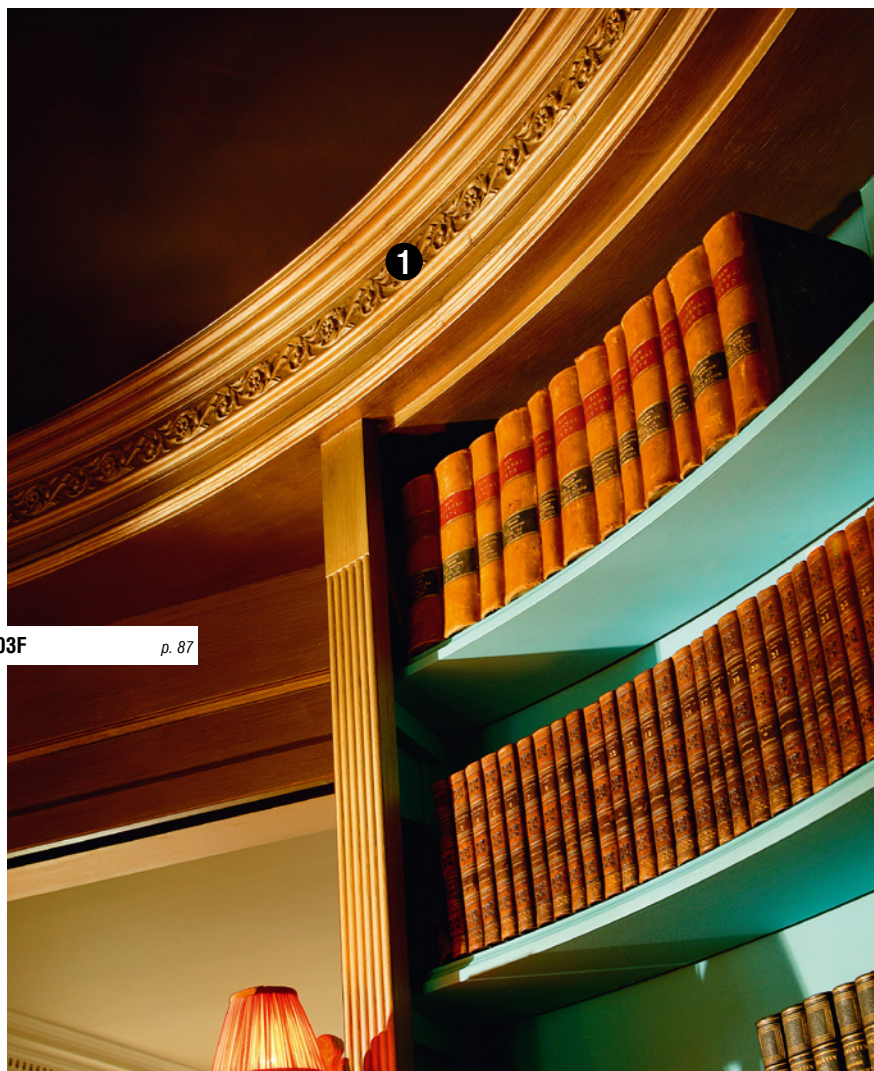

1 C303F p. 87

LUXXUS	cm		cm
	R min	<b>C339F</b>	380
<b>C200F</b>	160	<b>C341F</b>	400
<b>C201F</b>	200	<b>C373F</b>	100
<b>C211F</b>	250	<b>C374F</b>	130
<b>C212F</b>	120	<b>C402F</b>	300
<b>C213F</b>	280	<b>C602F</b>	100
<b>C214F</b>	140	<b>C901F</b>	600
<b>C215F</b>	160	<b>C902F</b>	600
<b>C216F</b>	340		
<b>C217F</b>	380		
<b>C218F</b>	360		
<b>C220F</b>	400		
<b>C230F</b>	150		
<b>C240F</b>	270		
<b>C250F</b>	70		
<b>C260F</b>	130		
<b>C301F</b>	320		
<b>C302F</b>	250		
<b>C303F</b>	180		
<b>C304F</b>	250		
<b>C308F</b>	120		
<b>C321F</b>	140		
<b>C322F</b>	160		
<b>C331F</b>	420		
<b>C333F</b>	300		
<b>C334F</b>	380		

AXXENT	cm
	R min
<b>CX100F</b>	200
<b>CX109F</b>	160
<b>CX110F</b>	180
<b>CX124F</b>	160
<b>CX127F</b>	240
<b>CX132F</b>	70
<b>CX148F</b>	180



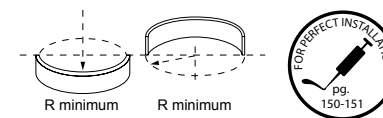

- |   |              |       |
|---|--------------|-------|
| ❶ | C307 + C307A | p. 90 |
| ❷ | C354         | p. 82 |



## pl

Wprowadź życie w swoje płaskie ściany dzięki naszej szerokiej gamie paneli ściennych. Stwórz na ścianach i sufitach atrakcyjne boazerie lub ościeżnice w szybki i wygodny sposób. Wszystkie dostępne wzory są łatwe w instalacji, a wiele profili jest dostępnych w wersji elastycznej do stosowania na wygiętych powierzchniach ścian i sufitów.

## fr

Animer un mur uni, c'est ce que nous appelons le « wallscaping ». Le vaste choix de cimaises permet de créer en un clin d'œil un lambris ou un encadrement sur le mur ou le plafond. Elles sont en outre faciles à poser et bon nombre d'entre elles sont disponibles en version flexible.

## en

Make flat walls come to life using "wallscaping" with our extensive panel mould range. Create attractive panelling or frames on walls and ceilings in a jiffy. All designs are easy to install, and many are available in a flexible format for use on curved walls and ceilings.

## ru

Оживите прямые стены с помощью широкого ассортимента молдингов. Создайте привлекательные панели или рамки на стенах в один миг. Все дизайны легко устанавливаются. Много моделей доступны также в гибком виде для использования на изогнутых или закругленных стенах или потолках.

## ar

جعل الجدران العادية تنبض بالحياة هو ما نسميه الـ "wallscaping". بفضل التشكيلة الواسعة من قوالب وألواح الجدران، يمكن خلق تلييسات أو إطارات على الحائط أو السقف في لمح البصر. القوالب سهلة التركيب، وعدد كبير منها متوفر أيضا بصيغة مرنة.

Profile

Cimaises

Panel Mouldings

Молдинги

قوالب للجدران





**P9050 | P9050F** LUXXUS

200 x 2,5 x 1,3 cm  
Purotouch®



**P5021 | P5021F** LUXXUS

200 x 3,1 x 0,9 cm  
Purotouch®

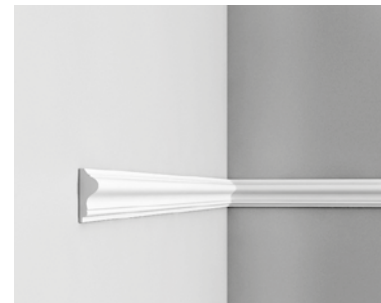

**P8030 | P8030F** LUXXUS

200 x 4,1 x 1,7 cm  
Purotouch®



**P2020 | P2020F** LUXXUS

200 x 4,4 x 2,6 cm  
Purotouch®



**P1020 | P1020F** LUXXUS

200 x 4,9 x 2,4 cm  
Purotouch®



**P9040 | P9040F** LUXXUS

200 x 5 x 2,5 cm  
Purotouch®



**P4020 | P4020F** LUXXUS

200 x 5 x 2,9 cm  
Purotouch®

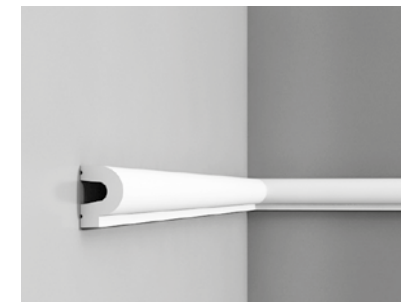

**P8060 | P8060F** LUXXUS

200 x 5 x 3,5 cm  
Purotouch®





**P8020 | P8020F**

LUXXUS

200 x 6 x 2,6 cm  
Purotouch®



**P3020 | P3020F**

LUXXUS

200 x 6,1 x 3,2 cm  
Purotouch®



**P6020 | P6020F**

LUXXUS

200 x 6,4 x 2,8 cm  
Purotouch®



**P9901 | P9901F**

LUXXUS

200 x 7 x 1,4 cm  
Purotouch®



**P7070 | P7070F**

LUXXUS

200 x 7,4 x 2,2 cm  
Purotouch®



**P7040 | P7040F**

LUXXUS

200 x 7,9 x 2,6 cm  
Purotouch®



**P9900 | P9900F**

LUXXUS

200 x 8 x 1 cm  
Purotouch®



**P5051**

LUXXUS

200 x 8,4 x 1,5 cm  
Purotouch®  
Designed by  
Jacques Vergracht







**P7030 | P7030F**

LUXXUS

200 x 8,5 x 1,7 cm  
Purotouch®



**P5020 | P5020F**

LUXXUS

200 x 9,1 x 1,3 cm  
Purotouch®



**P9010 | P9010F**

LUXXUS

200 x 9,1 x 3 cm  
Purotouch®



p. 129



**DX119-2300**

LUXXUS

230 x 9,2 x 2,2 cm  
Duropolymer®



p. 129



**DX121-2300**

LUXXUS

230 x 9,4 x 2,3 cm  
Duropolymer®



p. 129



**P9020 | P9020F**

LUXXUS

200 x 9,6 x 2,1 cm  
Purotouch®



**P8040 | P8040F**

LUXXUS

200 x 10,1 x 2,2 cm  
Purotouch®

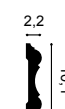

**P7010 | P7010F**

LUXXUS

200 x 10,5 x 2 cm  
Purotouch®





**P7020 | P7020F**

LUXXUS

200 x 11,1 x 1,9 cm  
Purotouch®



**DX170-2300 HERITAGE**

LUXXUS

230 x 11,9 x 3,2 cm  
Duropolymer®



p. 129

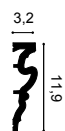

**P8050 | P8050F**

LUXXUS

200 x 12 x 3 cm  
Purotouch®

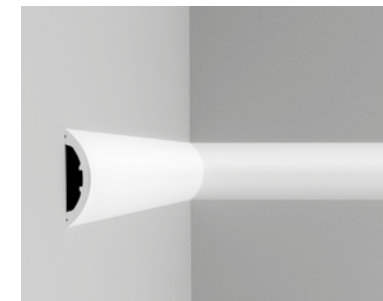

**P3070 RADIUS**

ULF MORITZ

200 x 12,5 x 3,2 cm  
Purotouch®  
Designed by  
Ulf Moritz



**P5050**

LUXXUS

200 x 20 x 1,5 cm  
Purotouch®  
Designed by  
Jacques Vergracht

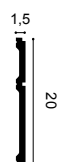

**P7080**

LUXXUS

200 x 21,8 x 2,9 cm  
Purotouch®

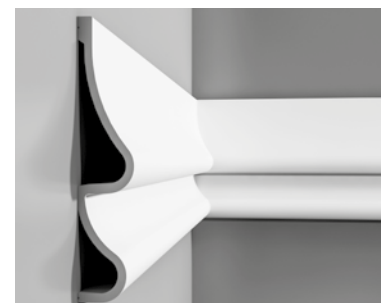

**P3071 GOLF**

ULF MORITZ

200 x 37,2 x 7,6 cm  
Purotouch®  
Designed by  
Ulf Moritz





**PX103 | PX103F**

AXXENT

200 x 2,5 x 1,2 cm  
Duopolymer®

1,2  
2,5



**PX116**

AXXENT

200 x 3,1 x 1 cm  
Duopolymer®

1  
3,1



**PX117**

AXXENT

200 x 3,5 x 1,5 cm  
Duopolymer®

1,5  
3,5

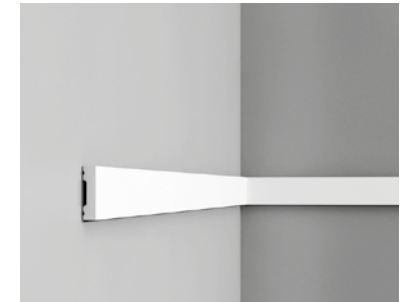

**DX162-2300**

AXXENT

230 x 4 x 1 cm  
Duopolymer®

1  
4



p. 129



**PX120 | PX120F**

AXXENT

200 x 4 x 1,9 cm  
Duopolymer®

1,9  
4

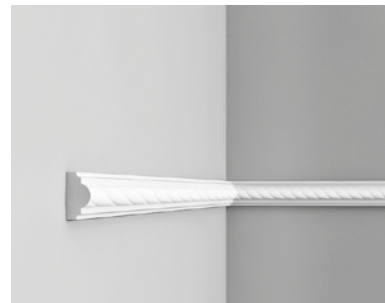

**PX131**

AXXENT

200 x 4 x 1,9 cm  
Duopolymer®

1,9  
4



**PX144 | PX144F**

AXXENT

200 x 4,7 x 0,8 cm  
Duopolymer®

0,8  
4,7



**PX145**

AXXENT

200 x 4,7 x 0,8 cm  
Duopolymer®

0,8  
4,7



**PX146** AXSENT  
200 x 4,7 x 0,8 cm  
Duropolymer®



**PX113** AXSENT  
200 x 6 x 2,7 cm  
Duropolymer®



**PX114** AXSENT  
200 x 6 x 2,7 cm  
Duropolymer®

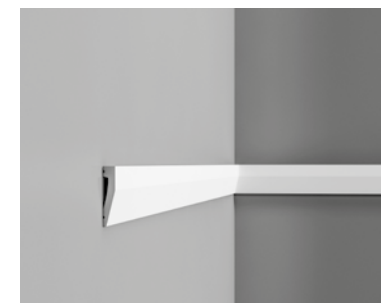

**DX159-2300** AXSENT  
230 x 6 x 1,2 cm  
Duropolymer®



**DX157-2300 | DX157F** AXSENT  
230 x 6,6 x 1,3 cm (DX157-2300)  
200 x 6,6 x 1,3 cm (DX157F)  
Duropolymer®



**PX102** AXSENT  
200 x 7,9 x 1,6 cm  
Duropolymer®



**DX163-2300** AXSENT  
230 x 10,2 x 1,3 cm  
Duropolymer®

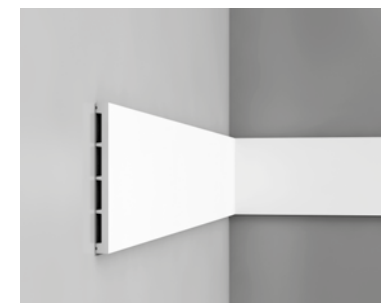

**DX168-2300** AXSENT  
230 x 15,1 x 1,4 cm  
Duropolymer®





**PX164**

AXXENT

200 x 2,4 x 3 cm  
Duropolymer<sup>®</sup>



**PX147**

200 x 16,9 x 0,9 cm  
Duropolymer<sup>®</sup>

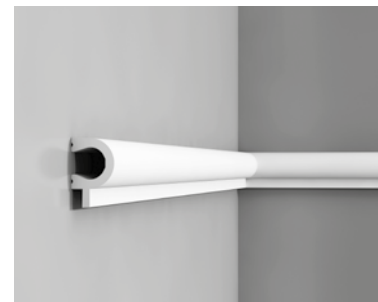
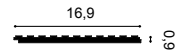

**PX169**

200 x 5,5 x 3,4 cm  
Duropolymer<sup>®</sup>



**PX147 + PX169**

AXXENT

Duropolymer<sup>®</sup>



**CX134**

AXXENT

200 x 3 x 3 cm  
Duropolymer<sup>®</sup>

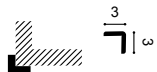

- |   |            |        |
|---|------------|--------|
| 1 | PX164      | p. 108 |
| 2 | DX163-2300 | p. 107 |
| 3 | DX157-2300 | p. 107 |
| 4 | DX163-2300 | p. 107 |
| 5 | DX162-2300 | p. 106 |

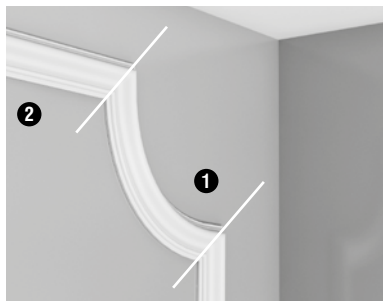

❶ P8030C + P8030 ❷

19 x 8,6 x 1,7 cm  
Duropolymer<sup>®</sup>



P8030D

LUXXUS

13,2 x 13,2 x 1,7 cm  
Duropolymer<sup>®</sup>



❶ P801C + P8020 ❷

19,8 x 11 x 2,6 cm  
Purotouch<sup>®</sup>

LUXXUS



P4020A + P4020

LUXXUS

16,4 x 9,1 x 2,9 cm  
Purotouch<sup>®</sup>

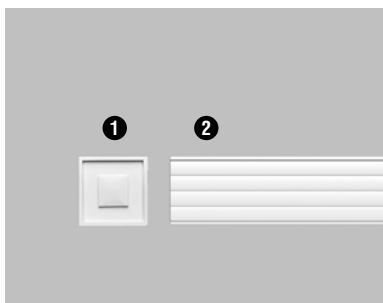

❶ P5020B + P5020 ❷

9 x 9 x 1,3 cm  
Purotouch<sup>®</sup>

LUXXUS

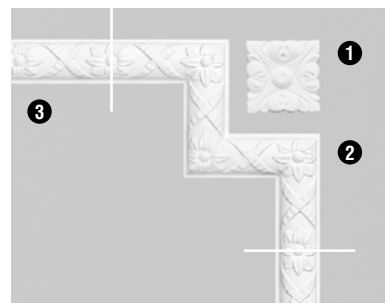
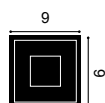

❶ P21

LUXXUS

6,7 x 6,7 x 0,9 cm  
Purotouch<sup>®</sup>

❷ P201A + P2020 ❸

LUXXUS

19,5 x 19,5 x 2,6 cm  
Purotouch<sup>®</sup>

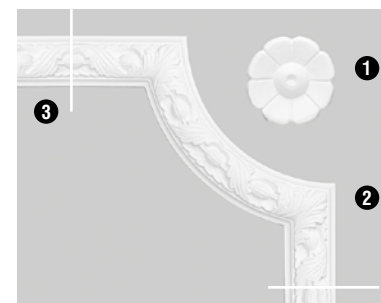

❶ P20

LUXXUS

Ø 6,1 x 0,8 cm  
Duropolymer<sup>®</sup>

❷ P101A + P1020 ❸

LUXXUS

24,5 x 24,5 x 2,4 cm  
Purotouch<sup>®</sup>

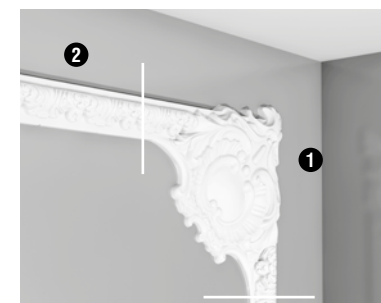

❶ P3020A + P3020 ❷

LUXXUS

42,5 x 42,5 x 4 cm  
Purotouch<sup>®</sup>

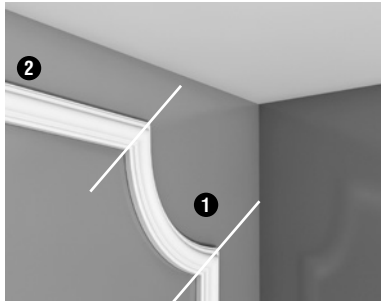

1 PX120A + PX120 2 AXXENT

19 x 8,8 x 2 cm  
Duropolymer®

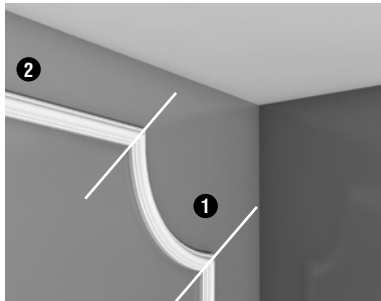

1 PX103A + PX103 2 AXXENT

19 x 3,5 x 1,2 cm  
Duropolymer®



- |          |        |
|----------|--------|
| 1 C217   | p. 85  |
| 2 P8030D | p. 109 |
| 3 P8030  | p. 102 |
| 4 P9010  | p. 104 |
| 5 SX118  | p. 116 |

# ORAC FLEX (REF + F)

Profile / Cimaises / Panel Mouldings / Молдинги / قوالب للجدران



AXXENT	cm	cm
	R min	R* min
<b>DX157F</b>	35	260
<b>PX103F</b>	20	80
<b>PX120F</b>	30	110
<b>PX144F</b>	20	220

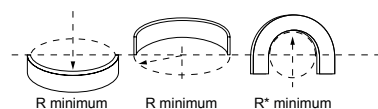

LUXXUS	cm	cm
	R min	R* min
<b>P1020F</b>	30	80
<b>P2020F</b>	30	80
<b>P3020F</b>	50	180
<b>P4020F</b>	40	200
<b>P5020F</b>	30	
<b>P5021F</b>	20	70
<b>P6020F</b>	30	250
<b>P7010F</b>	20	

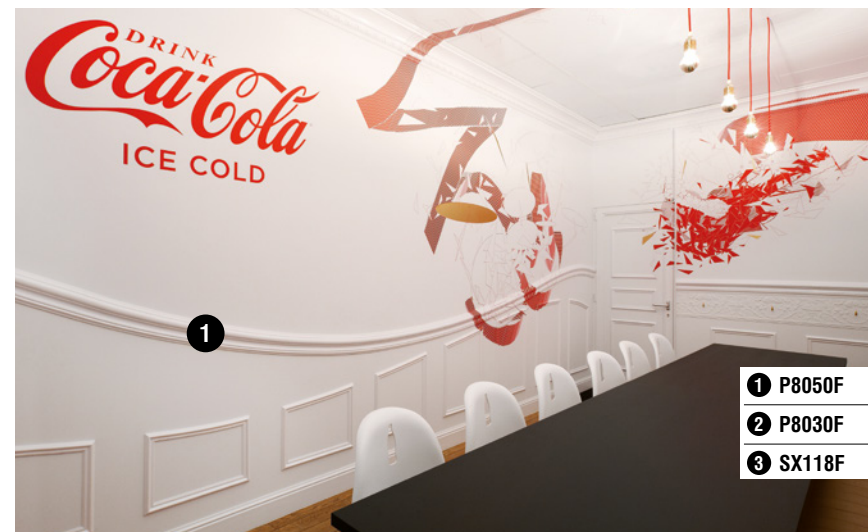

<b>1 P8050F</b>	p. 105
<b>2 P8030F</b>	p. 102
<b>3 SX118F</b>	p. 116

LUXXUS	cm	cm	LUXXUS	cm	cm	LUXXUS	cm	cm
	R min	R* min		R min	R* min		R min	R* min
<b>P1020F</b>	30	80	<b>P7020F</b>	30		<b>P8060F</b>	80	200
<b>P2020F</b>	30	80	<b>P7030F</b>	30	250	<b>P9010F</b>	40	310
<b>P3020F</b>	50	180	<b>P7040F</b>	40	320	<b>P9020F</b>	30	
<b>P4020F</b>	40	200	<b>P7070F</b>	30	230	<b>P9040F</b>	30	80
<b>P5020F</b>	30		<b>P8020F</b>	40	130	<b>P9050F</b>	20	60
<b>P5021F</b>	20	70	<b>P8030F</b>	20	70	<b>P9900F</b>	20	250
<b>P6020F</b>	30	250	<b>P8040F</b>	30		<b>P9901F</b>	20	180
<b>P7010F</b>	20		<b>P8050F</b>	80	200			





## pl

Wszystkie listwy przy-  
podłogowe są wykonane z  
duropolimeru – mieszaniny  
polimerów odpornej na  
uderzenia i zamoczenia,  
w całości nadającej się do  
recyclingu. Wszelkiego  
rodzaju kable i przewody  
mogą być z łatwością ukryte  
pod listwami, a elasty-  
czne wersje pozwalają na  
eleganckie wykończenie  
zakrzywionych powierzchni  
ścian. Dzięki wstępnemu  
gruntowaniu listwy są łatwe  
do malowania.

## fr

Toutes les plinthes sont en  
Duropolymer®, un mélange  
polymère résistant à l'eau et  
aux impacts qui est 100 %  
recyclable. Elles permettent  
d'aisément dissimuler les  
câbles, et les variantes  
flexibles sont idéales pour  
une finition élégante de  
murs cintrés. Par ailleurs,  
les plinthes sont livrées avec  
une couche de peinture pri-  
maire et peuvent facilement  
être mises en peinture.

## en

All skirting boards are made  
from Duropolymer®, an  
impact- and water-resistant  
polymer mix that is fully  
recyclable. Cables can  
be hidden easily, and the  
flexible versions allow curved  
walls to be finished elegantly.  
The skirting boards are pre-  
primed for easy painting.

## ru

Все плинтусы сделаны из  
материала дюрополимер  
(Duropolymer®) – ударо-  
прочного и водостойкого  
полимера. Скрывает про-  
водку. Любая изогнутая  
или закругленная стена  
может быть красиво отде-  
лана гибкими моделями.  
Плинтусы имеют загрун-  
тованная поверхность для  
легкости окрашивания.

## ar

جميع النعلات مصنوعة من  
دوروبوليمر، مزيج بوليمرات  
مقاوم للماء والصدمات وقابل  
لإعادة التدوير بالكامل. يمكن إخفاء  
الكابلات بسهولة، ويمكن إستعمال  
القوالب المرنة لتزيين الجدران  
المقوسة بشكل أنيق. النعلات  
مدهونة مسبقا بأساس لتسهيل  
عملية الطلاء.

Listwy przypodłogowe

Plinthes

Skirting

ПЛИНТУСЫ

نعلات



Listwy przypodłogowe / Plinthes / Skirting  
 Плинтусы / نعلات



**CX132 | CX132F**

AXXENT

200 x 2 x 2 cm  
 Duropolymer<sup>®</sup>

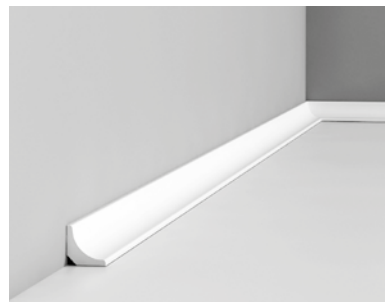

**CX133**

AXXENT

200 x 2 x 2 cm  
 Duropolymer<sup>®</sup>



**DX162-2300**

AXXENT

230 x 4 x 1 cm  
 Duropolymer<sup>®</sup>



**DX159-2300**

AXXENT

230 x 6 x 1,2 cm  
 Duropolymer<sup>®</sup>



**DX157-2300 | DX157F**

AXXENT

230 x 6,6 x 1,3 cm (DX157-2300)  
 200 x 6,6 x 1,3 cm (DX157F)  
 Duropolymer<sup>®</sup>



**SX165 | SX165F**

AXXENT

200 x 6,9 x 1,1 cm  
 Duropolymer<sup>®</sup>



**SX125**

AXXENT

200 x 6,9 x 1,4 cm  
 Duropolymer<sup>®</sup>



**SX122**

AXXENT

200 x 7,9 x 2,2 cm  
 Duropolymer<sup>®</sup>



Listwy przypodłogowe / Plinthes / Skirting  
 ПЛИНТУСЫ / نعلات



**SX137**

AXXENT

200 x 9,9 x 1,5 cm  
 Duropolymer<sup>®</sup>

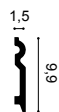

**DX163-2300**

AXXENT

230 x 10,2 x 1,3 cm  
 Duropolymer<sup>®</sup>

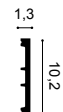

**SX105 | SX105F**

LUXXUS

200 x 10,8 x 1,3 cm  
 Duropolymer<sup>®</sup>



**SX155 | SX155F**

LUXXUS

200 x 10,8 x 2,5 cm  
 Duropolymer<sup>®</sup>



1 SX118

p. 116

1



**SX138**

AXXENT

200 x 13,8 x 1,5 cm  
 Duropolymer<sup>®</sup>

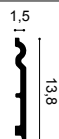

**SX118 | SX118F**

LUXXUS

200 x 13,8 x 1,8 cm  
 Duropolymer<sup>®</sup>



**SX104**

LUXXUS

200 x 14,8 x 1,7 cm  
 Duropolymer<sup>®</sup>



**DX168-2300**

AXXENT

230 x 15,1 x 1,4 cm  
 Duropolymer<sup>®</sup>

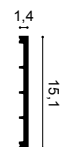

**SX167 DUNE**

ULF MORITZ

200 x 17,3 x 4,3 cm  
 Duropolymer<sup>®</sup>  
 Designed by Ulf Moritz



**SX156 HIGH HEELS**

LUXXUS

200 x 20 x 1,6 cm  
 Duropolymer<sup>®</sup>  
 Designed by  
 Xavier Donck



# ORAC FLEX (REF + F)

Listwy przypodłogowe / Plinthes / Skirting / Плинтусы / نعلات



**LUXXUS** cm

R min

<b>SX105F</b>	30
<b>SX118F</b>	40
<b>SX155F</b>	30

**AXXENT** cm

R min

R\* min

<b>CX132F</b>	70	
<b>DX157F</b>	35	260
<b>SX165F</b>	40	

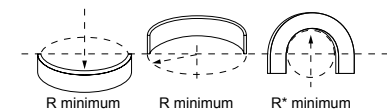



## pl

Listwy oświetleniowe dzięki rozproszonemu światłu tworzą przytulną atmosferę i efekt większej przestrzeni. Bez względu na to czy zastosujemy światło linearne czy rozproszone, dolne czy górne, jedno jest pewne: uatrakcyjnią to wizualną stronę architektury. Co więcej, kompaktowe oświetlenie LED jest trwałym i energooszczędnym rozwiązaniem.

## fr

Incontournable pour l'ambiance, l'éclairage indirect crée une illusion d'espace supplémentaire. Qu'il soit linéaire ou organique, à luminosité vers le bas ou vers le haut, l'éclairage indirect souligne indubitablement l'architecture. Grâce à l'éclairage LED compact, vous disposez en outre d'une solution économique dont la longévité est garantie.

## en

Indirect lighting imparts a warm atmosphere and creates an extra spatial effect. Whether tautly linear or diffuse, as uplight or downlight, one thing is certain: it enhances the architecture. What's more, the compact LED lighting ensures an energy-efficient and durable solution.

## ru

Скрытое освещение создает теплую атмосферу и дополнительный эффект пространства. Каким бы не было освещение прямым или рассеянным, сверху или снизу, ясно одно: он совершенствует архитектуру. Более того, компактная светодиодная подсветка обеспечивает энергоэффективное и надежное решение.

## ar

الإضاءة غير المباشرة تضيفي جوا دافئا وتخلق إنطبعاا بمساحة إضافية. سواء كانت مستقيمة أو منتشرة، موجهة نحو الأعلى أو الأسفل، إنها بالتأكيد تعزز الهندسة الداخلية. إضافة إلى ذلك، إضاءة LED المدمجة تؤمن حلا موفرا للطاقة ومستداما.

Listwy Oświetleniowe  
Éclairage Indirect  
Indirect Lighting  
Скрытое освещение  
إضاءة غير مباشرة

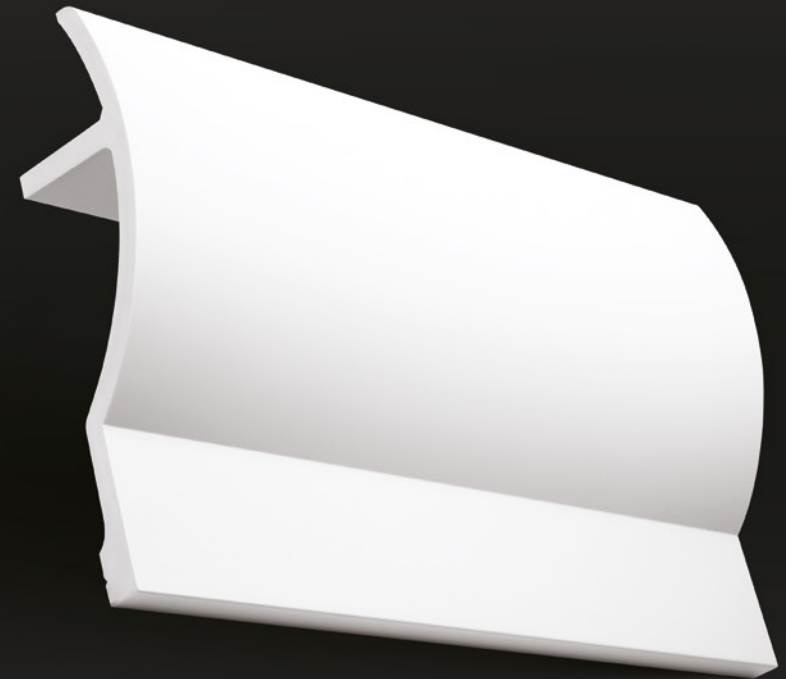



Listwy Oświetleniowe / Éclairage Indirect / Indirect Lighting  
 Скрытое освещение / إضاءة غير مباشرة



**C351 BOAT** LUXXUS

200 x 7,4 x 17,3 cm  
 Purotouch<sup>®</sup>  
 Designed by Jacques Vergracht

17,3 cm  
 7,4 cm  
 $\sphericalangle = 19$

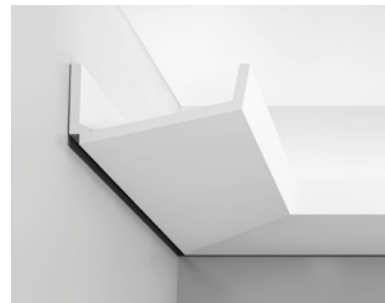

**C352 FLAT** LUXXUS

200 x 7,6 x 17,1 cm  
 Purotouch<sup>®</sup>  
 Designed by Jacques Vergracht

17,1 cm  
 7,6 cm  
 $\sphericalangle = 18,1$

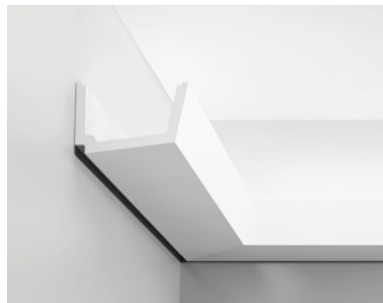

**C357 STRAIGHT** LUXXUS

200 x 7,1 x 11 cm  
 Purotouch<sup>®</sup>  
 Designed by Jacques Vergracht

11 cm  
 7,1 cm  
 $\sphericalangle = 12,6$

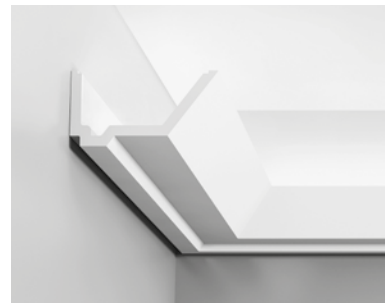

**C358 RAIL** LUXXUS

200 x 7,3 x 14 cm  
 Purotouch<sup>®</sup>  
 Designed by Jacques Vergracht

14 cm  
 7,3 cm  
 $\sphericalangle = 15,3$



**1 C352 FLAT** p. 120



1 C364 WAVE p. 121



**C361 STRIPE**

LUXXUS

200 x 5 x 5 cm  
 Purotouch<sup>®</sup>  
 Designed by  
 Pierre Daems

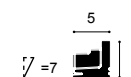

**C364 WAVE**

LUXXUS

200 x 14 x 8 cm  
 Purotouch<sup>®</sup>  
 Designed by  
 Pierre Daems  
 Red Dot Design Award 2014

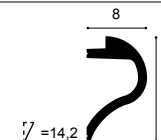

**C362 CURVE**

LUXXUS

200 x 5 x 5 cm  
 Purotouch<sup>®</sup>  
 Designed by  
 Pierre Daems

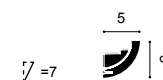



- ❶ C991 *p. 70*
- ❷ C374 ANTONIO *p. 123*
- ❸ C373 ANTONIO *p. 123*
- ❹ SX167 DUNE *p. 116*



❶ C373 ANTONIO *p. 123*

Listwy Oświetleniowe / Éclairage Indirect / Indirect Lighting  
 Скрытое освещение / إضاءة غير مباشرة

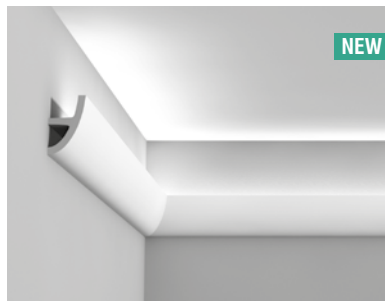

**C373 | C373F ANTONIO** ULF MORITZ

200 x 8 x 5 cm  
 Purotouch<sup>®</sup>  
 Designed by  
 Ulf Moritz

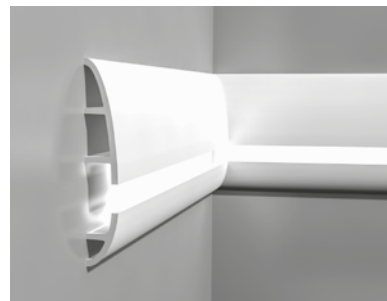
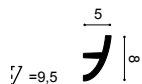

**C374 ANTONIO + C373 ANTONIO**



**C374 | C374F ANTONIO** ULF MORITZ

200 x 18 x 5 cm  
 Purotouch<sup>®</sup>  
 Designed by  
 Ulf Moritz

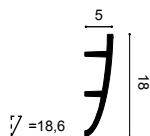

Plafond / Ceiling / Decke / Techo

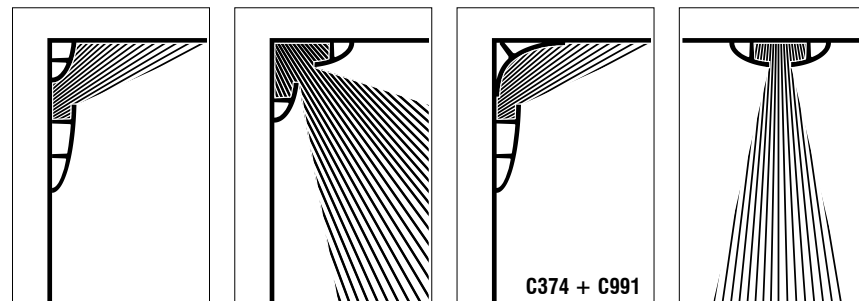

Muur / Mur / Wall / Wand / Pared

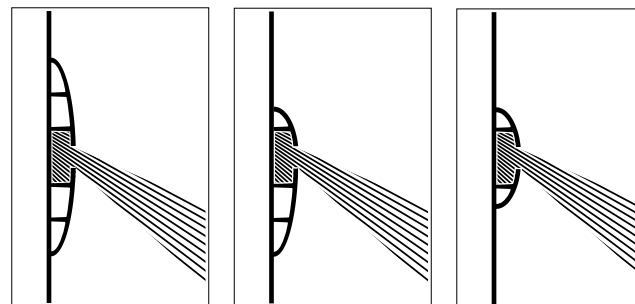

Vloer / Sol / Floor / Boden / Suelo

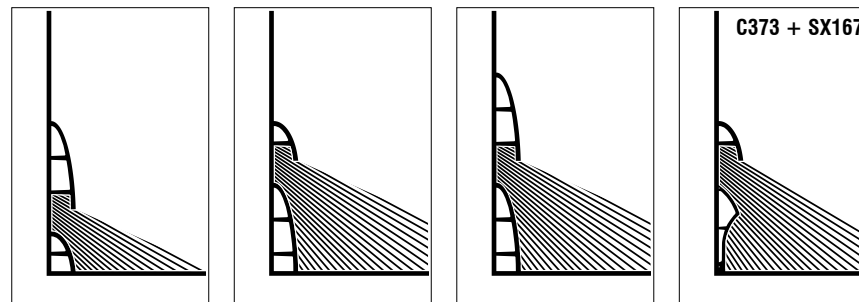



- ❶ C371 SHADE *p. 125*
- ❷ C374 ANTONIO *p. 123*
- ❸ C373 ANTONIO *p. 123*

Listwy Oświetleniowe / Éclairage Indirect / Indirect Lighting  
 Скрытое освещение / إضاءة غير مباشرة



**C991**

ULF MORITZ

200 x 11 x 14 cm  
 Purotouch<sup>®</sup>  
 Designed by  
 Ulf Moritz

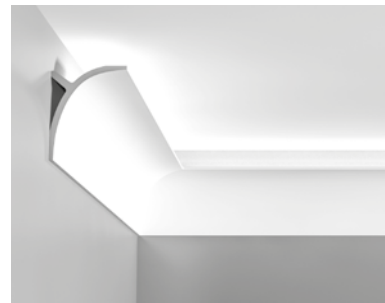
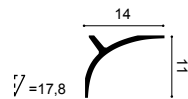

**C900**

LUXXUS

200 x 17,1 x 14,6 cm  
 Purotouch<sup>®</sup>

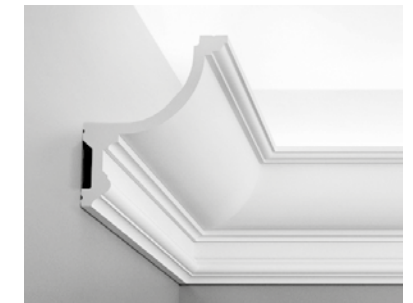
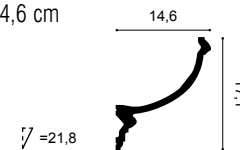

**C901**

LUXXUS

200 x 14,8 x 12,4 cm  
 Purotouch<sup>®</sup>

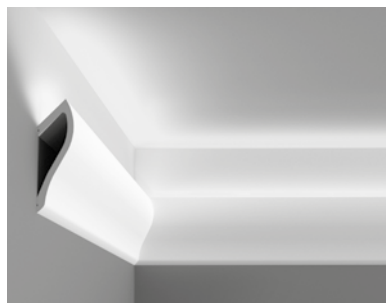
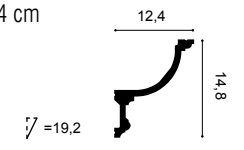

**C371 SHADE**

ULF MORITZ

200 x 18,5 x 5,8 cm  
 Purotouch<sup>®</sup>  
 Designed by  
 Ulf Moritz

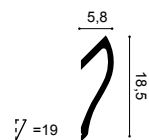

**C372 FLUXUS**

ULF MORITZ

200 x 28 x 7 cm  
 Purotouch<sup>®</sup>  
 Designed by  
 Ulf Moritz

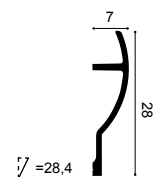

**C902**

LUXXUS

200 x 10,3 x 10,3 cm  
 Purotouch<sup>®</sup>

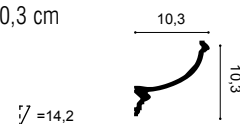

**LIGHTING TIPS !**

**LED**  
 INFO: P152  
 INSTALLATION: P153



## pl

Podążaj za swoją wyobraźnią. Dzięki naszym elementom dekoracyjnym można stworzyć zarówno subtelne jak i dostojne klasyczne wnętrza. Eleganckie i nowoczesne wzornictwo można zaaranżować we współczesnych domach dzięki wyrazistym formom 3D. Te ornamentalne elementy znacznie podnoszą możliwości personalizacji pomieszczeń.

## fr

Donnez libre cours à votre imagination. Sobres et dignes dans un intérieur classique, contemporains dans une habitation moderne ou plutôt un résultat 3D éclectique ? Ces ornements aux applications infinies rendent chaque pièce unique.

## en

Follow your imagination. Understated and dignified classic interiors, can be created with our Deco elements. The sleek, modern designs suit contemporary homes, by adding a dramatic 3D form? The elements of these ornaments allow considerable opportunities to personalize any room.

## ru

Дайте волю своему воображению. Любые классические интерьеры могут быть созданы благодаря нашим декоративным элементам. Стильный и минималистический в классическом дизайне или современный с добавлением в него 3D модели? Элементы этих орнаментов предоставляют значительные возможности в персонализации любого помещения.

## ar

أطلقوا العنان لمخيلتكم. تصميم هادئ وأنيق لداخل كلاسيكي. معاصر لمسكن حديث، أو متنوع وثلاثي الأبعاد؟ هذه الأصناف الزينية تمكنكم من جعل كل غرفة فريدة من نوعها.

Elementy Dekoracyjne  
Eléments Décoratifs  
Deco Elements  
Декоративные элементы  
أصناف للزينة







**P9010** LUXXUS

200 x 9,1 x 3 cm  
 Purotouch<sup>®</sup>



NEW

**DX170-2300** LUXXUS

230 x 11,9 x 3,2 cm  
 Duropolymer<sup>®</sup>



NEW

**D330LR** LUXXUS

12,6 x 16 x 4,1 cm  
 Duropolymer<sup>®</sup>



**D210** LUXXUS

9,6 x 9,6 x 3,5 cm  
 Duropolymer<sup>®</sup>

**DX121-2300** LUXXUS

230 x 9,4 x 2,3 cm  
 Duropolymer<sup>®</sup>



**D310** LUXXUS

9,5 x 24,9 x 3,1 cm  
 Duropolymer<sup>®</sup>

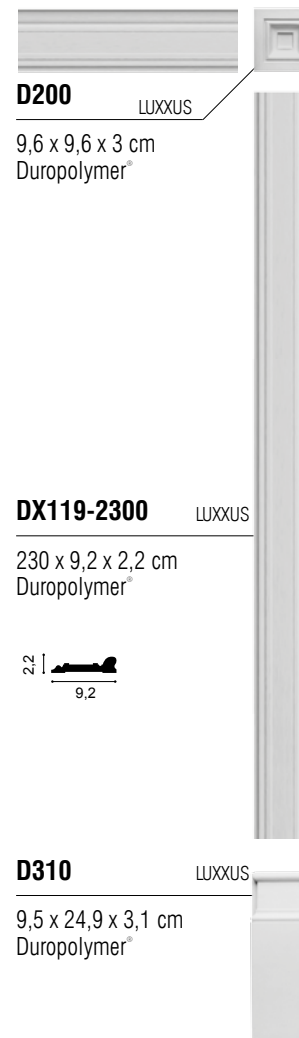

**D200** LUXXUS

9,6 x 9,6 x 3 cm  
 Duropolymer<sup>®</sup>

**DX119-2300** LUXXUS

230 x 9,2 x 2,2 cm  
 Duropolymer<sup>®</sup>

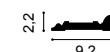

**D310** LUXXUS

9,5 x 24,9 x 3,1 cm  
 Duropolymer<sup>®</sup>

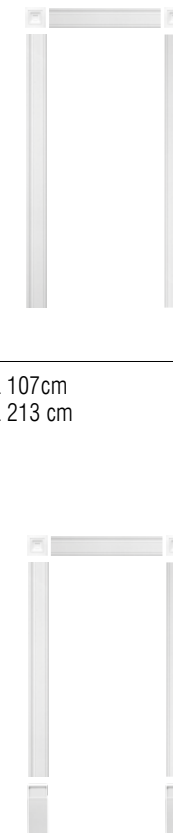

**KIT KX001**

1 x DX119, L 107cm  
 2 x DX119, L 213 cm  
 2 x D200



**KIT KX003**

1 x DX119, L 107cm  
 2 x DX119, L 190 cm  
 2 x D200  
 2 x D310

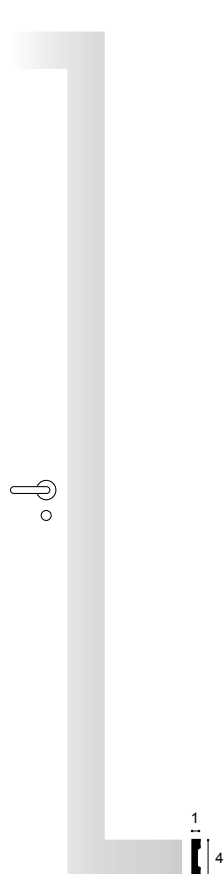

**DX162-2300**

AXXENT

230 x 4 x 1 cm  
 Duropolymer<sup>®</sup>

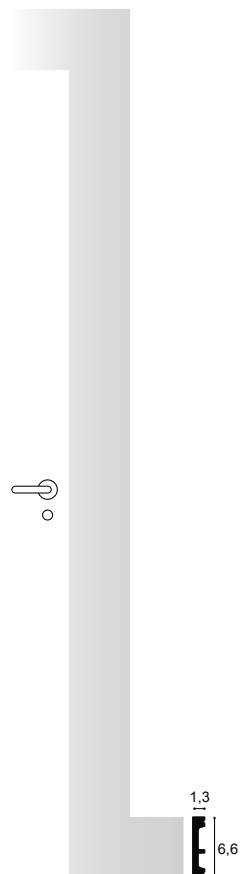

**DX157-2300**

AXXENT

230 x 6,6 x 1,3 cm  
 Duropolymer<sup>®</sup>

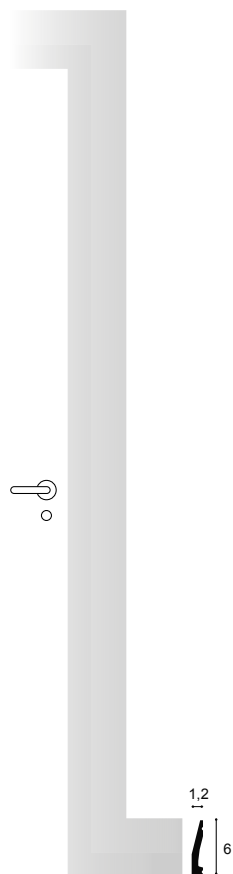

**DX159-2300**

AXXENT

230 x 6 x 1,2 cm  
 Duropolymer<sup>®</sup>

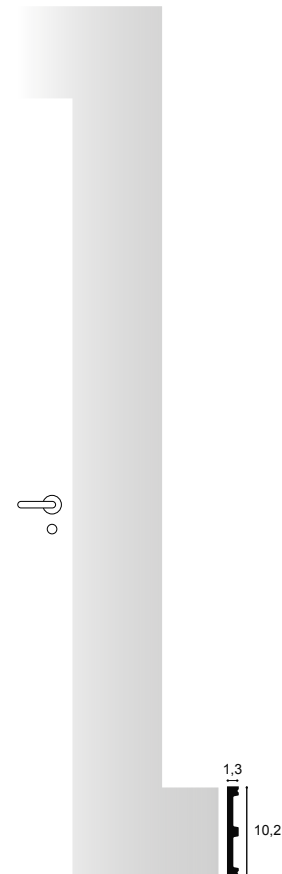

**DX163-2300**

AXXENT

230 x 10,2 x 1,3 cm  
 Duropolymer<sup>®</sup>

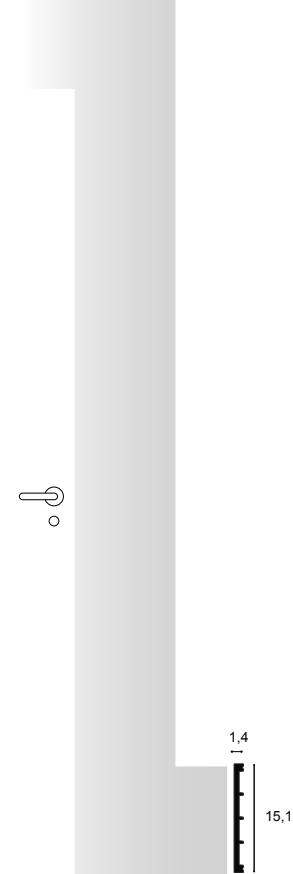

**DX168-2300**

AXXENT

230 x 15,1 x 1,4 cm  
 Duropolymer<sup>®</sup>



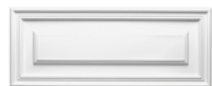

**D504**

LXXXUS

55 x 22 x 1,7 cm  
Duropolymer<sup>®</sup>



**F30**

LXXXUS

59,5 x 59,5 x 4,3 cm  
Purotouch<sup>®</sup>

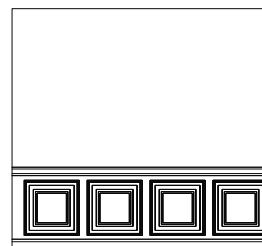

P9010  
F30  
SX118

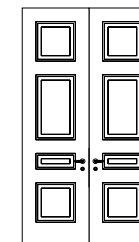

D503  
D507  
D504  
D503

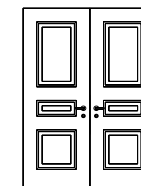

D507  
D504  
D503



**D500**

LXXXUS

55 x 74,7 x 1,6 cm  
Duropolymer<sup>®</sup>

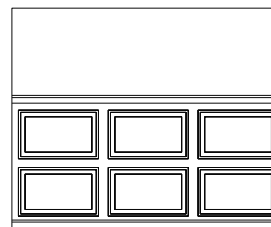

P8050  
D507  
SX156

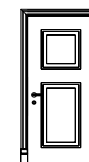

DX121-2300 + D310  
D503  
D507

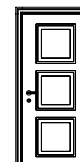

DX119-2300  
3x D503



**D503**

LXXXUS

55 x 55 x 1,7 cm  
Duropolymer<sup>®</sup>



**D507**

LXXXUS

55 x 90,5 x 1,7 cm  
Duropolymer<sup>®</sup>



**D506**

LXXXUS

43 x 43 x 1,7 cm  
Duropolymer<sup>®</sup>

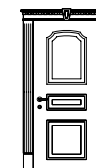

D401 + D402  
2x K200 + D320  
D500  
D504  
D503

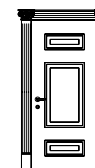

K201L + K200 + K201R  
2x K200  
D504  
D507  
D504  
D320



**PX147**

AXSENT

200 x 16,9 x 0,9 cm  
Duropolymer<sup>®</sup>

**A**

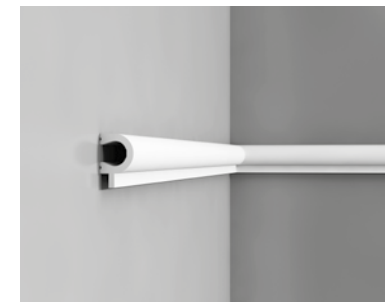

**PX169**

AXSENT

200 x 5,5 x 3,4 cm  
Duropolymer<sup>®</sup>

**B**



**PX147 + PX169**

**A + B**



**D140**

LUXXUS

98,5 x 31,5 x 2,5 cm  
Purotouch<sup>®</sup>



**D120**

LUXXUS

124 x 25 x 9 cm  
Purotouch<sup>®</sup>



**D402**

LUXXUS

15 x 12,1 x 5,8 cm  
Purotouch<sup>®</sup>  
(only for D400 and D401)



**D161**

LUXXUS

92 x 23 x 3,7 cm  
Purotouch<sup>®</sup>



**D400**

LUXXUS

127,5 x 14,5 x 5,5 cm  
Purotouch<sup>®</sup>

**D400 + D402**



**D170**

LUXXUS

105 x 24,5 x 3,2 cm  
Purotouch<sup>®</sup>



**D401**

LUXXUS

127,5 x 14,5 x 5,5 cm  
Purotouch<sup>®</sup>

**2 x D401 + D402**



Obudowy kominków / Cheminées Décoratives / Decorative Mantel Pieces / Декоративная облицовка для камина  
مواقد زينية

Nisze / Niches /  
Niches / Ниши / محاريب

ORAC®  
DECOR

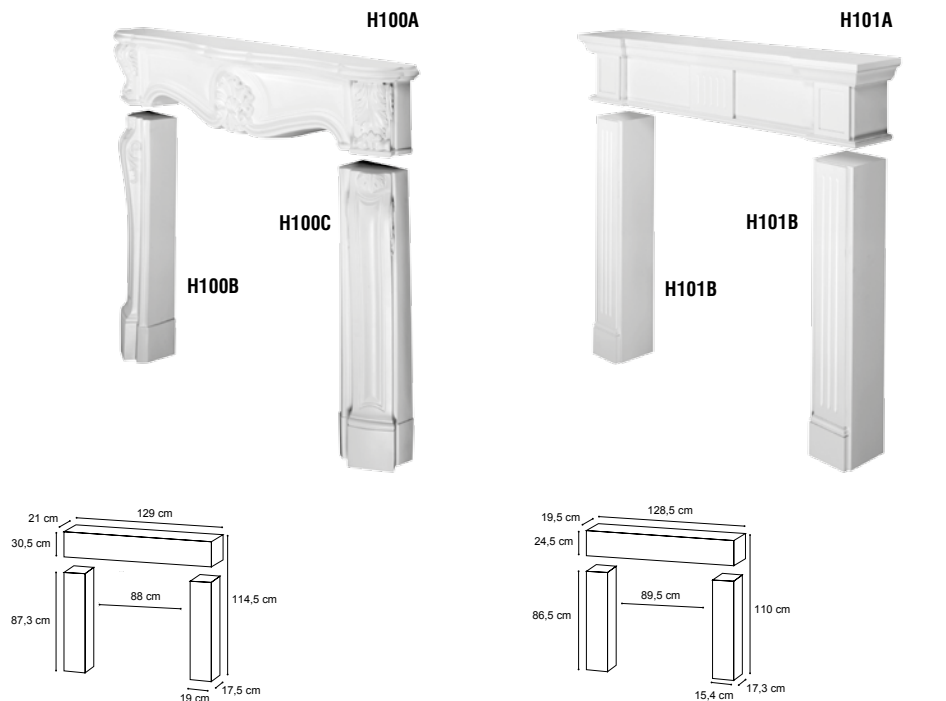

**H100**

LUXXUS

114,5 x 129 x 21 cm  
Purotouch®

**H101**

LUXXUS

110 x 128,5 x 19,5 cm  
Purotouch®

**N503**

1 LUXXUS

69,5 x 113,5 x 11,1 cm  
Purotouch®

**N504**

2 LUXXUS

69,5 x 114 x 10,9 cm  
Purotouch®

**N510**

3 LUXXUS

55,3 x 98,5 x 18 cm  
Purotouch®

**N520**

4 LUXXUS

55,5 x 98,5 x 18 cm  
Purotouch®



(cm)	A	B	C	AA	
N503	69,5	113,5	11,1	51,5	
N504	69,5	114,0	10,9	49,5	
(cm)	F	G	H	FF	GG
N510	55,3	98,5	18,0	53,0	96,0
N520	55,5	98,5	18,0	53,0	92,0

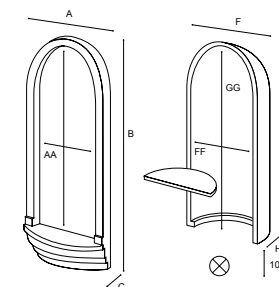

max. 2 à 3 kW

Obudowy kominków są jedynie elementami dekoracyjnymi i mogą być instalowane wyłącznie z grzejnikami elektrycznymi o maks. mocy 2 do 3 kW.  
Les cheminées sont des éléments décoratifs. Elles peuvent seulement être employées avec un feu électrique de max. 2 à 3 kW.  
The fireplaces are just as decorative purposes and should only be installed in conjunction with an electric heater up to 2 to 3 kW.  
Камины являются только декоративными элементами. Они используются только для электрических каминов, макс. мощность 2-3 кВт.  
المواقد هي للزينة فقط، ولا يمكن إستعمالها إلا مع شعلة كهربائية لا تتعدى ٢-٣ كيلوواط.

Umieść żarówkę (max. 60W) w odległości co najmniej 10 cm od dna.  
Installez l'ampoule (max. 60W) à 10cm minimum du fond opaque.  
Place the bulb (max. 60W) at least 10cm of soil opal.  
Устанавливать лампочку (макс. Мощность 60Вт) на расстоянии не менее 10 см. от оргстекла ниши.  
تركب اللبمة (٦٠ واط كحد أقصى) على مسافة ١٠ سم على الأقل من الأسفل

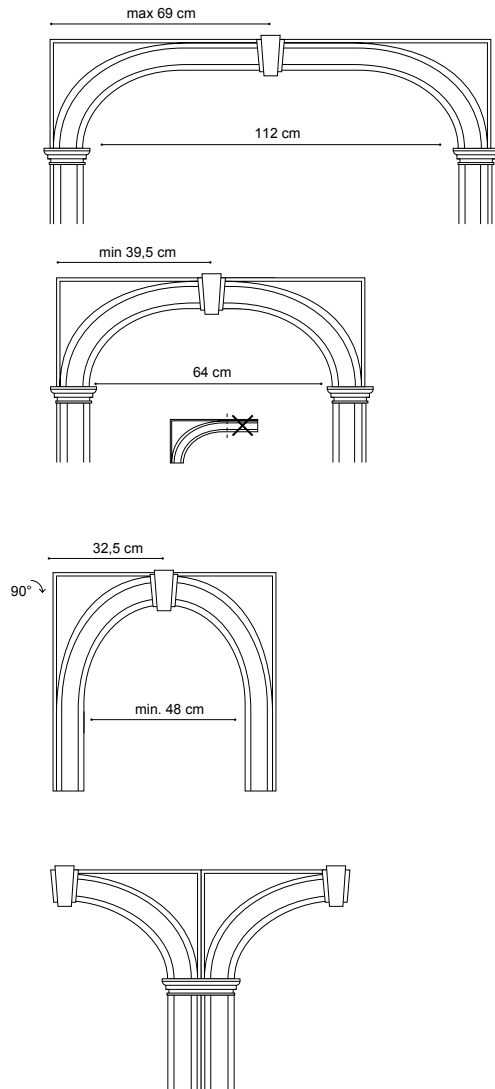

**M9010LR**

64,2 x 32 x 3 cm  
Duropolymer<sup>®</sup>

**P9010**

200 x 9,1 x 3 cm  
Purotouch<sup>®</sup>

**D300**

9,5 x 26 x 3,7 cm  
Duropolymer<sup>®</sup>

**M9010R**

LUXXUS

**M9010L**

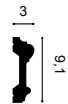

LUXXUS

LUXXUS

**M9010A**

LUXXUS

LUXXUS

LUXXUS

LUXXUS

**P9010**

**M9010C**

22,5 x 5,2 x 4,9 cm  
Duropolymer<sup>®</sup>

**M9010B**

12,6 x 5,2 x 4,9 cm  
Duropolymer<sup>®</sup>

**M9010A**

9,5 x 4,5 x 11,6 cm  
Duropolymer<sup>®</sup>

**D310**

8,5 x 24,9 x 3,1 cm  
Duropolymer<sup>®</sup>

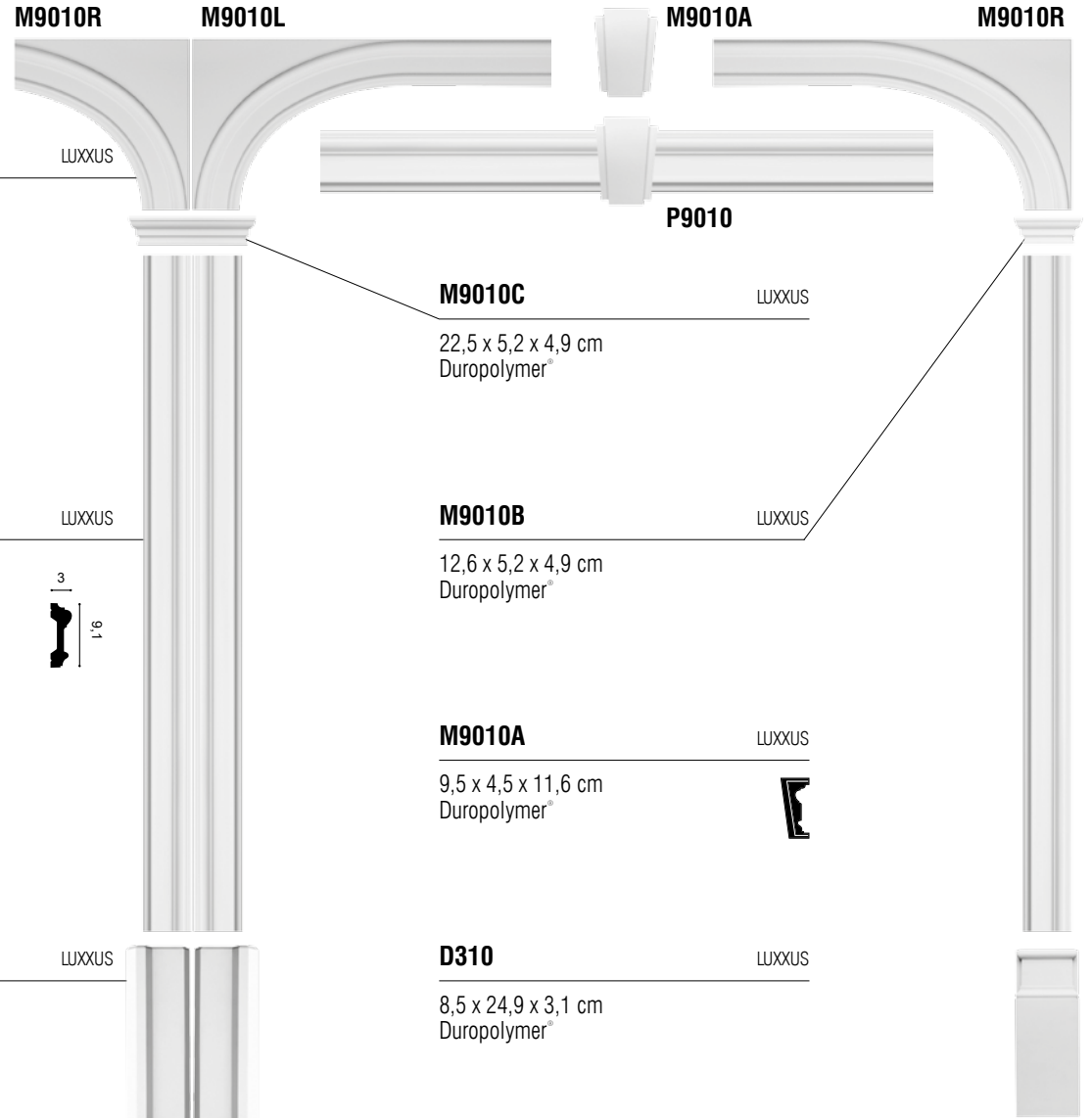

Byblos

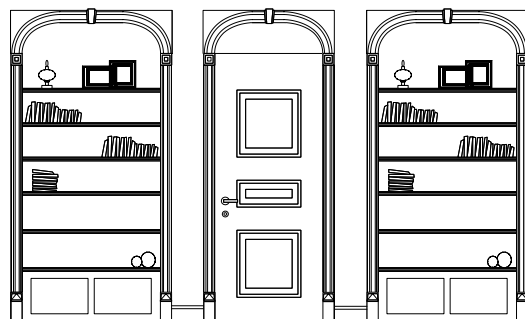

M9010L, M9010A, M9010R  
D200, P9010, D300, D503, D504, SX118

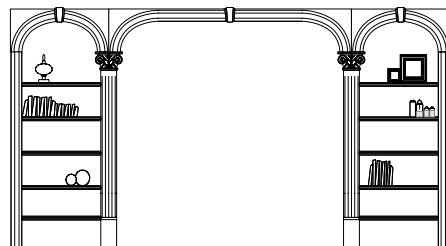

M9010L, M9010A, M9010R  
K200, K201, D320

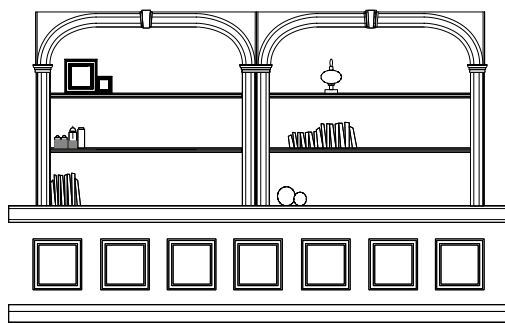

M9010L, M9010A, M9010R, M9010B, M9010C  
P9010, P9020, D506, SX105

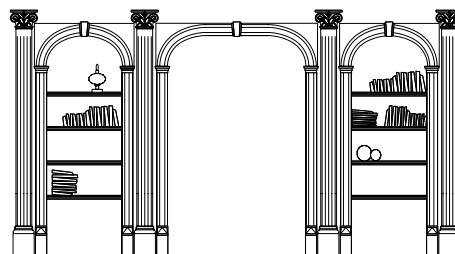

M9010L, M9010A, M9010R, M9010B  
K201, K200, K202, P9010, D310

Kinkiety / Appliques /  
Fixtures / Светильники / مصابيح للجدران

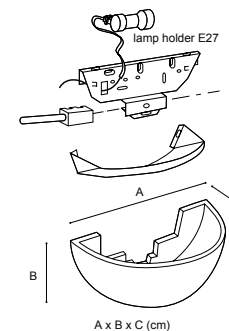

**L504**

LUXXUS

30,5 x 15,3 x 15 cm  
Duropolymer®



**L505**

LUXXUS

40,8 x 11,5 x 16,3 cm  
Duropolymer®



Rozety / Rosaces /  
Ceiling Roses / Потолочные розетки / ورديات للسقوف

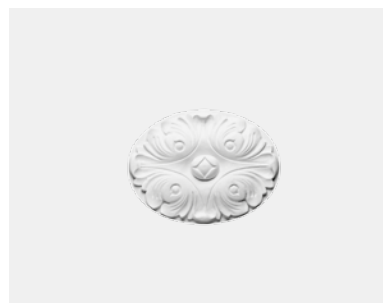
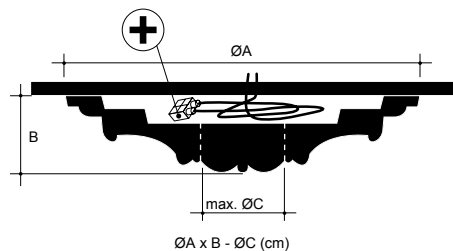

**D62** LUXXUS

15,6 x 11,6 x 1,4 cm  
Purotouch<sup>®</sup>

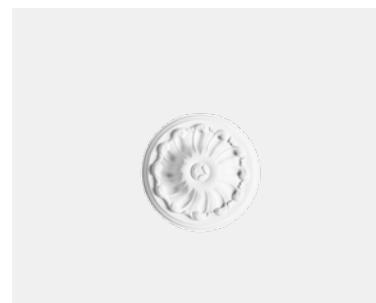

**R10** LUXXUS

ø 15 x 4,2 - ø 2 cm  
Purotouch<sup>®</sup>



**R11** LUXXUS

ø 19 x 3,6 - ø 3 cm  
Purotouch<sup>®</sup>

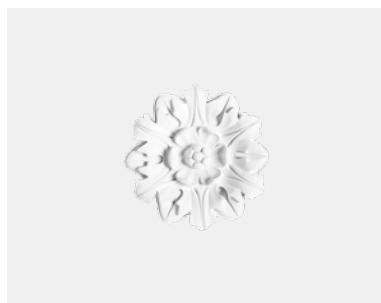

**R12** LUXXUS

ø 19,5 x 1,8 - ø 1 cm  
Purotouch<sup>®</sup>

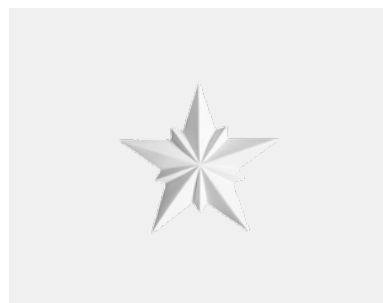

**R35** LUXXUS

ø 20,5 x 2,7 cm  
Purotouch<sup>®</sup>

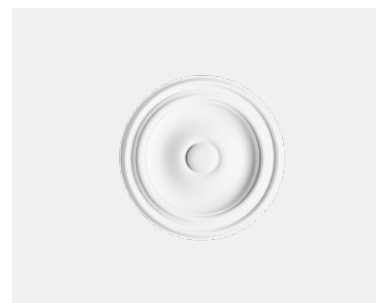

**R07** LUXXUS

ø 26 x 3 - ø 5 cm  
Purotouch<sup>®</sup>

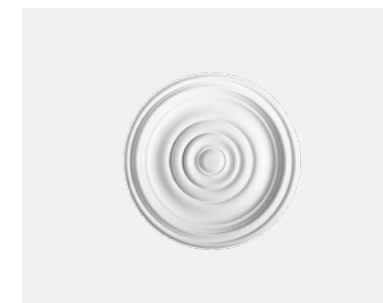

**R08** LUXXUS

ø 38 x 4,2 - ø 5 cm  
Purotouch<sup>®</sup>



**R13** LXXXUS

ø 28 x 3,1 - ø 2,5 cm  
Purotouch<sup>®</sup>



**R50** LXXXUS

ø 32 x 3,8 - ø 19 cm  
Purotouch<sup>®</sup>



**R14** LXXXUS

ø 33 x 3 - ø 2,5 cm  
Purotouch<sup>®</sup>



**R31** LXXXUS

ø 38,5 x 2,7 - ø 3,5 cm  
Purotouch<sup>®</sup>



**R61** LXXXUS

ø 40 x 3,1 - ø 2,5 cm  
Purotouch<sup>®</sup>



**R17** LXXXUS

ø 47 x 3,5 - ø 6,5 cm  
Purotouch<sup>®</sup>

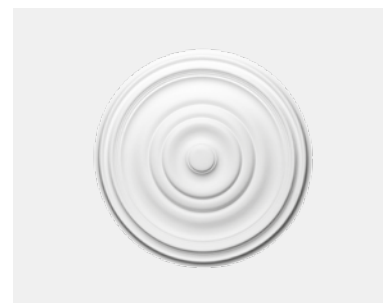

**R09** LXXXUS

ø 48,5 x 3,7 - ø 6 cm  
Purotouch<sup>®</sup>



**R18** LXXXUS

ø 49 x 4,7 - ø 7 cm  
Purotouch<sup>®</sup>



**R46** LUXXUS

ø 53,5 x 4,2 - ø 3 cm  
Purotouch<sup>®</sup>



**R66** LUXXUS

ø 54,5 / 43 x 2,4 cm  
Purotouch<sup>®</sup>

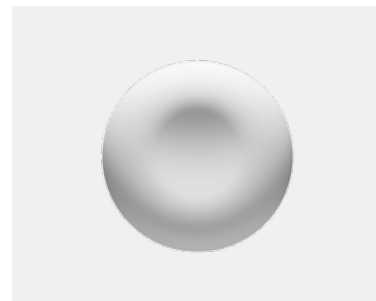

**R70** ULF MORITZ

ø 60 x 7,7 cm  
Purotouch<sup>®</sup>

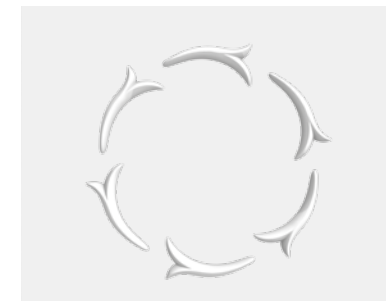

**6x G77 LILY** ULF MORITZ

ø 50 cm / G77: 19,4 x 8,8 x 1,8 cm  
Duropolymer<sup>®</sup>



**R76** LUXXUS

ø 62 x 4,1 - ø 10,5 cm  
Purotouch<sup>®</sup>



**R77** LUXXUS

ø 62 x 4,2 - ø 10,5 cm  
Purotouch<sup>®</sup>

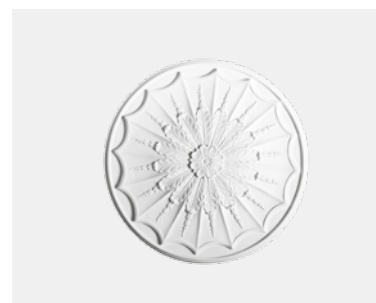

**R28** LUXXUS

ø 68,5 x 5,2 - ø 2 cm  
Purotouch<sup>®</sup>



**R52** LUXXUS

ø 69,5 x 4,8 - ø 12,5 cm  
Purotouch<sup>®</sup>





**R73** LUXXUS

ø 70 x 5,9 - ø 8 cm  
Purotouch<sup>®</sup>



**R38** LUXXUS

ø 71 x 4,2 - ø 19 cm  
Purotouch<sup>®</sup>



**R23** LUXXUS

ø 71 x 4,4 - ø 6 cm  
Purotouch<sup>®</sup>



**R40** LUXXUS

ø 74,5 x 3,1 - ø 10 cm  
Purotouch<sup>®</sup>



**R27** LUXXUS

ø 75 x 4,5 - ø 9 cm  
Purotouch<sup>®</sup>



**R22** LUXXUS

77,5 x 53 x 3,6 cm  
Purotouch<sup>®</sup>



**R24** LUXXUS

ø 79 x 6 - ø 8 cm  
Purotouch<sup>®</sup>



**R64** LUXXUS

ø 95,2 x 4,8 - ø 7 cm  
Purotouch<sup>®</sup>





**F30** LUXXUS

59,5 x 59,5 x 4,3 cm  
Purotouch<sup>®</sup>

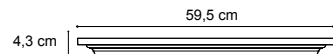

**F31** LUXXUS

59,5 x 59,5 x 6,6 cm  
Purotouch<sup>®</sup>

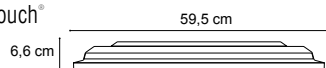

**F12** LUXXUS

34 x max. diam. 133,5 cm  
Purotouch<sup>®</sup>

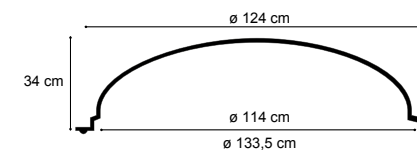

**F10** LUXXUS

11,2 x max. diam. 90 cm  
Purotouch<sup>®</sup>

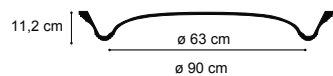

**F11** LUXXUS

9,5 x max. diam. 74,5 cm  
Purotouch<sup>®</sup>

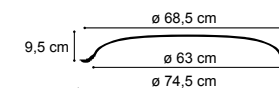



**G40** LXXXUS

16,4 x 13,4 x 1,5 cm  
Duropolymer<sup>®</sup>



**D200** LXXXUS

9,6 x 9,6 x 3 cm  
Duropolymer<sup>®</sup>

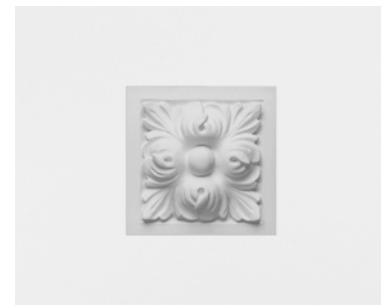

**D210** LXXXUS

9,6 x 9,6 x 3,5 cm  
Duropolymer<sup>®</sup>



**P5020B** LXXXUS

9 x 9 x 1,3 cm  
Purotouch<sup>®</sup>



**G42** LXXXUS

39,8 x 4,4 x 1,9 cm  
Duropolymer<sup>®</sup>



**P21** LXXXUS

6,7 x 6,7 x 0,9 cm  
Duropolymer<sup>®</sup>

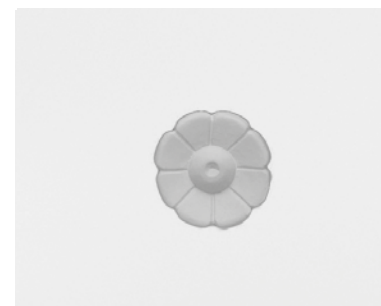

**P20** LXXXUS

Ø 6,1 - 0,8 cm  
Duropolymer<sup>®</sup>



**D62** LXXXUS

15,6 x 11,6 x 1,4 cm  
Purotouch<sup>®</sup>



**G70 FOLIO**

ULF MORITZ

20 x 9 x 2,7 cm  
 Duropolymer<sup>®</sup>

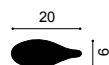

**G72 SMILE**

ULF MORITZ

42,5 x 6,8 x 1 cm  
 Duropolymer<sup>®</sup>

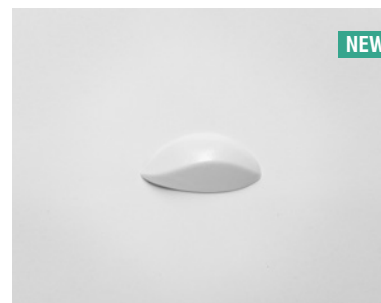
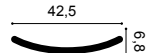

**G78 LILY**

ULF MORITZ

8,8 x 4,4 x 1,9 cm  
 Duropolymer<sup>®</sup>



**G77 LILY**

ULF MORITZ

19,4 x 8,8 x 1,8 cm  
 Duropolymer<sup>®</sup>



**G73L CURL MINI**

ULF MORITZ

20,1 x 18,1 x 1 cm  
 Purotouch<sup>®</sup>

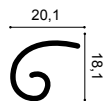

**G73R CURL MINI**

ULF MORITZ

20,1 x 18,1 x 1 cm  
 Purotouch<sup>®</sup>



**G74L CURL MAXI**

ULF MORITZ

25,4 x 24,4 x 1,1 cm  
 Purotouch<sup>®</sup>

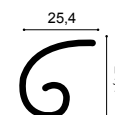

**G74R CURL MAXI**

ULF MORITZ

25,4 x 24,4 x 1,1 cm  
 Purotouch<sup>®</sup>

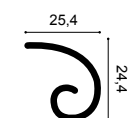

Elementy dekoracyjne / Éléments Décoratifs / Deco Elements  
 Декоративные элементы / أصناف للزينة



**G71 SCALA**

ULF MORITZ

42,2 x 35 x 1,5 cm  
 Purotouch®

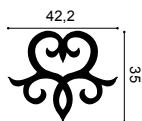

**G76 SCALA**

ULF MORITZ

8 x 17,8 x 1,5 cm  
 Purotouch®

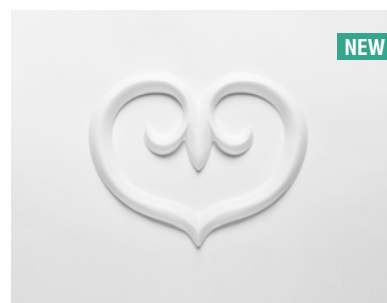

**G75 SCALA**

ULF MORITZ

27 x 21 x 1,4 cm  
 Purotouch®



Segmenty Kolumn / Colonnes Segmentées  
 Segmented Columns / Сборные колонны  
 أعمدة مجزأة

**K4132** (H 21,5 cm)



**5 x K4002** (H 72 cm)

**4 x K4002** (H 72 cm)

**3 x K4002** (H 72 cm)

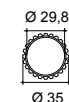

K4132 + 3xK4002 + K4122 = 274 cm H max  
 K4132 + 4xK4002 + K4122 = 345 cm H max  
 K4132 + 5xK4002 + K4122 = 416 cm H max

**K4122** (H 40cm)

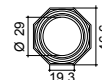

**K4131** (H 21,5 cm)



**5 x K4001** (H 72 cm)

**4 x K4001** (H 72 cm)

**3 x K4001** (H 72 cm)



K4131 + 3xK4001 + K4121 = 274 cm H max  
 K4131 + 4xK4001 + K4121 = 345 cm H max  
 K4131 + 5xK4001 + K4121 = 416 cm H max

**K4121** (H 40 cm)





# Peine Kolumny / Colonnas Entières / Full Columns Колонны / أعمدة كاملة

**K1142** (H 16 cm)



**K1142** (H 16 cm)

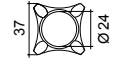

**K1112** (H 30 cm)

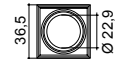

**K1112** (H 30 cm)

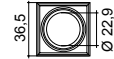

**K1122** (H 30 cm)

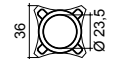

**K1122** (H 30 cm)

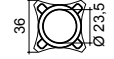

**K1002** (H 199,5 cm)



**K1102** (H 202 cm)



**K3142** (H 20 cm)



**K3142** (H 20 cm)



**K3142** (H 20 cm)



**K3112** (H 12,5 cm)

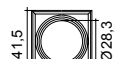

**K3112** (H 12,5 cm)



**K3112** (H 12,5 cm)



**K3002** (H 201 cm)

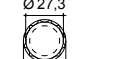

**K3102** (H 202 cm)



**K3202** (H 241,5 cm)

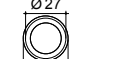

K1142 + K1002 + K1152 = 225 cm H  
K1142 + K1002 + K1132 = 270 cm H max  
K1112 + K1002 + K1152 = 242 cm H  
K1112 + K1002 + K1132 = 287 cm H max  
K1122 + K1002 + K1152 = 242 cm H  
K1122 + K1002 + K1132 = 287 cm H max

K1142 + K1102 + K1152 = 227,5 cm H  
K1142 + K1102 + K1132 = 272,5 cm H max  
K1112 + K1102 + K1152 = 244,5 cm H  
K1112 + K1102 + K1132 = max. 289,5 cm H max  
K1122 + K1102 + K1152 = 244,5 cm H  
K1122 + K1102 + K1132 = 289,5 cm H max

K3142 + K3002 + K2132 = 237 cm H  
K3142 + K3002 + K3152 = 275 cm H max  
K3112 + K3002 + K2132 = 233,5 cm H  
K3112 + K3002 + K3152 = 271,5 cm H max

K3142 + K3102 + K2132 = 237 cm H  
K3142 + K3102 + K3152 = 275 cm H max  
K3112 + K3102 + K2132 = 233,5 cm H  
K3112 + K3102 + K3152 = 271,5 cm H max

K3142 + K3202 + K2132 = 277,5 cm H  
K3142 + K3202 + K3152 = 315,5 cm H max  
K3112 + K3202 + K2132 = 274 cm H  
K3112 + K3202 + K3152 = 312 cm H max

**K1152** (H 12,5 cm)

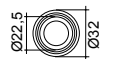

**K1152** (H 12,5 cm)

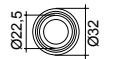

**K2132** (H 20 cm)

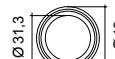

**K2132** (H 20 cm)



**K2132** (H 20 cm)



**K1132** (H 57,5 cm)



**K1132** (H 57,5 cm)



**K3152** (H 58 cm)

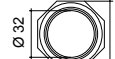

**K3152** (H 58 cm)



**K3152** (H 58 cm)



# Rólkolumny / Demi-Colonnes / Half Columns

## Полуколонны / نصف أعمدة

**K1141** (H 16 cm)



**K1111** (H 30 cm)



**K1121** (H 30 cm)



**K1001** (H 199,5 cm)



K1141 + K1001 + K1151 = 225 cm H  
 K1141 + K1001 + K1131 = 270 cm H max  
 K1111 + K1001 + K1151 = 242 cm H  
 K1111 + K1001 + K1131 = 287 cm H max  
 K1121 + K1001 + K1151 = 242 cm H  
 K1121 + K1001 + K1131 = 287 cm H max

**K1141** (H 16 cm)



**K1111** (H 30 cm)



**K1121** (H 30 cm)



**K1101** (H 202 cm)



K1141 + K1101 + K1151 = 227,5 cm H  
 K1141 + K1101 + K1131 = 272,5 cm H max  
 K1111 + K1101 + K1151 = 244,5 cm H  
 K1111 + K1101 + K1131 = max. 289,5 cm H max  
 K1121 + K1101 + K1151 = 244,5 cm H  
 K1121 + K1101 + K1131 = 289,5 cm H max

**K3141** (H 20 cm)



**K3111** (H 12,5 cm)



**K3001** (H 201 cm)



K3141 + K3001 + K2131 = 237 cm H  
 K3141 + K3001 + K3151 = 275 cm H max  
 K3111 + K3001 + K2131 = 233,5 cm H  
 K3111 + K3001 + K3151 = 271,5 cm H max

**K3141** (H 20 cm)



**K3111** (H 12,5 cm)



**K3101** (H 202 cm)



K3141 + K3101 + K2131 = 237 cm H  
 K3141 + K3101 + K3151 = 275 cm H max  
 K3111 + K3101 + K2131 = 233,5 cm H  
 K3111 + K3101 + K3151 = 271,5 cm H max

**K3141** (H 20 cm)



**K3111** (H 12,5 cm)



**K3201** (H 241,5 cm)

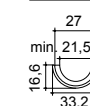

K3141 + K3201 + K2131 = 277,5 cm H  
 K3141 + K3201 + K3151 = 315,5 cm H max  
 K3111 + K3201 + K2131 = 274 cm H  
 K3111 + K3201 + K3151 = 312 cm H max

**K1151** (H 12,5 cm)



**K1131** (H 57,5 cm)



**K1151** (H 12,5 cm)



**K1131** (H 57,5 cm)



**K2131** (H 20 cm)



**K3151** (H 58 cm)



**K2131** (H 20 cm)



**K3151** (H 58 cm)



**K2131** (H 20 cm)



**K3151** (H 58 cm)



# Pilastry / Pilastres / Pilasters

## أعمدة مسطحة للجدران / Пиллястры

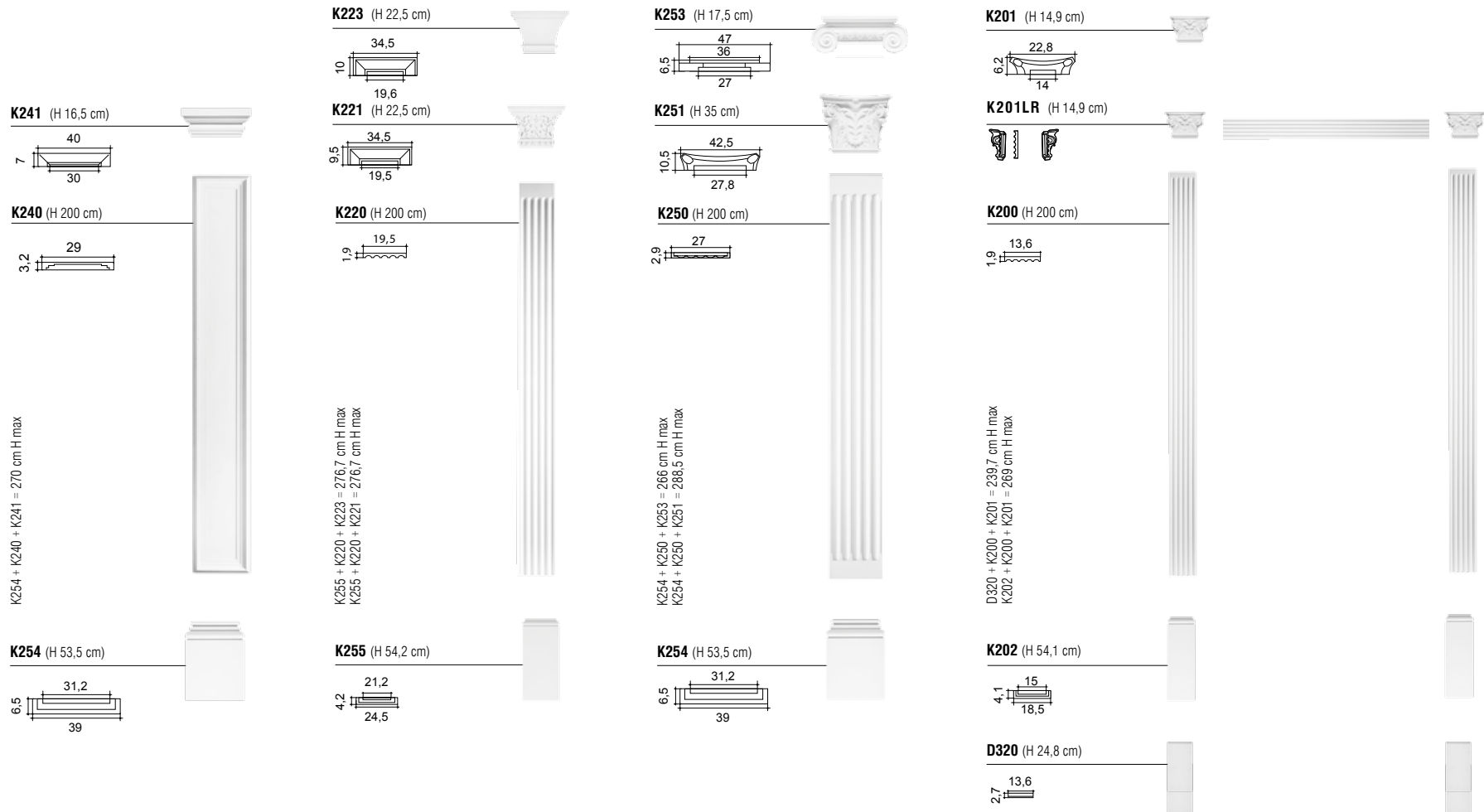

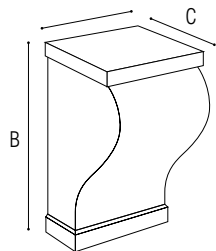

A x B x C (cm)



**B401** LXXXUS

11,6 x 15,4 x 7 cm  
Purotouch<sup>®</sup>

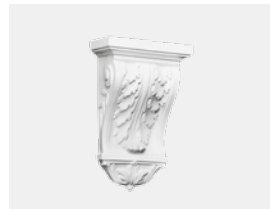

**B404** LXXXUS

19,3 x 31,5 x 11,3 cm  
Purotouch<sup>®</sup>

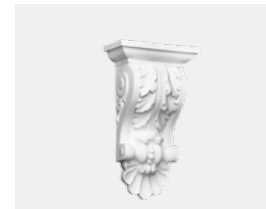

**B408** LXXXUS

21,5 x 39 x 12,6 cm  
Purotouch<sup>®</sup>

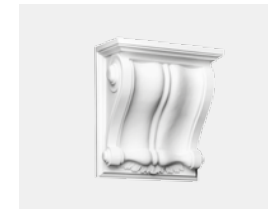

**B409** LXXXUS

30 x 35 x 17,5 cm  
Purotouch<sup>®</sup>



**B410** LXXXUS

19,3 x 49 x 15,8 cm  
Purotouch<sup>®</sup>

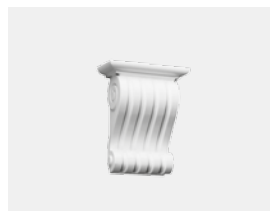

**B413** LXXXUS

16,5 x 22,7 x 8,5 cm  
Purotouch<sup>®</sup>

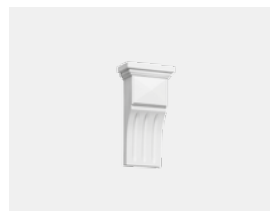

**B414** LXXXUS

10,1 x 22,5 x 7,2 cm  
Purotouch<sup>®</sup>

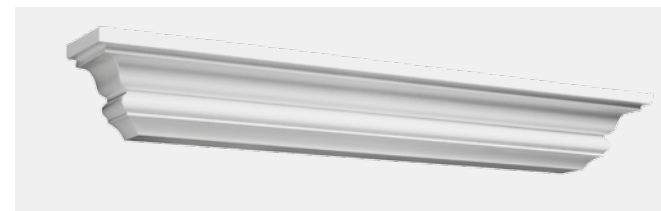

**B417** LXXXUS

90,6 x 12,5 x 14 cm  
Purotouch<sup>®</sup>



**GB02** LXXXUS

7 x 40 x 49 cm  
Duropolymer<sup>®</sup>



**GB03** LXXXUS

7 x 63 x 58 cm  
Duropolymer<sup>®</sup>



**GB04** LXXXUS

5 x 74,5 x 77 cm  
Duropolymer<sup>®</sup>



**TF02** LXXXUS

7,7 x 12 x 10,5 cm  
Duropolymer<sup>®</sup>



GB02 - GB03 - GB04 - TF02





Kleje i Akcesoria  
Colles et Accessoires  
Adhesives and Accessories  
Клей и Инструменты  
مواد لاصقة ولوازم



## DecoFix Pro



FDP500 310ml  
> 7 - 8m  
FDP600 4200ml  
> 65 - 110m

pl

**Wyjątkowo mocny klej instalacyjny do aplikacji we wnętrzach na porowatych powierzchniach**

- Mocny, akrylowy klej na bazie wody
- Długotrwałe uszczelnienie pomiędzy listwami, a ścianami lub sufitami
- Nadmiar usuwać za pomocą wilgotnej gąbki lub szmatki
- Chronić przed mrozem
- Nadaje się do malowania po całkowitym stwardnieniu (min. 24 godz.)

## DecoFix Hydro



FDP700 290ml  
> 7 - 8 m

**Wyjątkowo mocny klej MS polimerowy do stosowania na zewnątrz, na gładkich powierzchniach (płytki, szkło itp.) w wilgotnym środowisku**

- Usuwać rozwarem z mydła
- Nadaje się do malowania po całkowitym stwardnieniu (min. 24 godz.)

## DecoFix Extra



FX200 310ml  
> 80m  
FX210 80ml  
> 20m

**Poliuretanowy klej do łączeń pomiędzy listwami**

- Nadmiar kleju usuwać przed stwardnieniem (maks. 1 godz., powtórzyć po 2-3 godz.)
- Czyścić acetonem lub syntetycznymi rozpuszczalnikami
- Nadaje się do malowania po 24 godz.
- Wyższa wilgotność skraca czas schnięcia

fr

**Colle d'installation ultra forte pour surfaces poreuses et applications intérieures**

- Colle forte à base d'eau et d'acrylique
- Joint longue durée entre les moulures et le mur et/ou le plafond
- Retirez à l'aide d'une éponge ou d'un chiffon humide
- Doit être conservé à l'abri du gel
- Peut être peinte après séchage (min. 24 heures)

**Colle au MS polymère extra forte pour utilisation extérieure, surfaces non poreuses (carrelage, verre, etc...) et environnements humides**

- Enlevez à l'aide d'une solution savonneuse
- Peut être peinte après séchage (min. 24 heures)

**Colle polyuréthane pour l'assemblage des joints entre les moulures**

- Éliminez les excès de colle avant le durcissement (1 heure max. et recommencez après 2-3 heures)
- Nettoyez avec de l'acétone ou un diluant synthétique
- Peut être peint après 24 h
- Un taux d'humidité plus élevé peut accélérer le temps de séchage

en

**Extra strong installation adhesive for porous surfaces and interior applications**

- Strong, water-based acrylic glue
- Long-lasting seal between mouldings and the wall and/or ceiling
- Remove with humid sponge or cloth
- Should be kept frost free
- Paintable after hardening (min. 24 hours)

**Extra strong MS polymer glue for exterior applications, non-porous (tiles, glass, ...) surfaces and damp environments**

- Remove with soap solution
- Paintable after hardening (min. 24 hours)

**Polyurethane-based glue to seam joints between mouldings**

- Remove excess glue before hardening (max. 1 hour and repeat after 2-3 hours)
- Clean with acetone or Synth Thinner
- Can be painted after 24 hrs
- The more humidity, the faster the drying time

ru

**Монтажный клей для пористых поверхностей и внутреннего применения**

- Стойкий, акриловый клей на водной основе
- Долговечное соединение между молдингами и стеной и/или потолком
- Удаляется с помощью влажной губки или тряпки
- Хранить не замораживая
- Лепной декор можно окрашивать через 24 часа

**Монтажный полимерный клей и наполнитель для наружного применения, в помещениях с повышенной влажностью, непористых поверхностей (плитка, стекло, ...) вместо DecoFix Pro**

- Излишки клея удаляются мыльным раствором до застытия
- Лепной декор можно окрашивать через 24 часа

**Стыковочный клей на полиуретановой основе для соединительных швов лепного декора**

- Избыток клея предпочтительно удалять до затвердевания (макс 1 час и повтор каждые 2-3 часа)
- Излишки и пятна клея следует удалять с помощью ацетона или растворителя
- Лепной декор можно окрашивать через 24 часа
- Чем больше влажность, тем меньше время высыхания

ar

لاصق قوي جدا لتثبيت القوالب على أسطح مسامية وفي الداخل  
- لاصق أكريليك قوي، أساسه ماء  
- لاصق متين بين القوالب والجدار وأو السقف  
- يزال بإسفنجة أو قماش رطب  
- يحفظ محميا من الجليد  
- يمكن طلاؤه بعد أن يصلب (24 ساعة على الأقل)

لاصق م.س. بوليمر قوي جدا لتثبيت القوالب في الخارج، في أماكن رطبة، وعلى أسطح غير مسامية (بلاط، زجاج...)  
- يزال بالماء والصابون  
- يمكن طلاؤه بعد أن يصلب (24 ساعة على الأقل)

لاصق بوليوريثين للصلق الفواصل بين القوالب  
- يزال قاطن الغراء قبل أن يصلب  
- (بعد ساعة كحد أقص، ومجددا بعد 2-3 ساعات)  
- ينظف بأسيتون أو مرقق إصطناعي  
- يمكن طلاؤه بعد 24 ساعة  
- ينشف بسرعة أكبر مع ارتفاع درجة الرطوبة

PEŁNA GWARANCJA  
TYLKO Z DECOFIX

GARANTIE TOTALE  
UNIQUEMENT AVEC COLLE  
DECOFIX

ONLY FULL  
GUARANTEE WITH  
DECOFIX

ГАРАНТИЯ ДЕЙСТВУЕТ  
ТОЛЬКО ПРИ ИСПОЛЬЗОВАНИИ  
КЛЕЯ DECOFIX

ضمانة كاملة فقط مع  
ديكوفيكس



Wnętrze, suche i porowate powierzchnie  
Pose à l'intérieur, surfaces poreuses, pièces non humides  
Interior, porous and dry surface  
Для внутренних работ, сухих и пористых поверхностей  
سطح داخلي، مسامي وجاف



Na zewnątrz, powierzchnie wilgotne i gładkie  
Environnement humide, surfaces non poreuses, pose à l'extérieur  
Exterior, non-porous and humid surface  
Используйте DecoFix Hydro для наружного применения, в помещениях с повышенной влажностью, непористых поверхностей (плитка, стекло, ...) вместо DecoFix Pro  
سطح خارجي، غير مسامي ورطب



Aksesoria / Accessoires / Accessories / Принадлежности / لوازم



FDP100



FB15

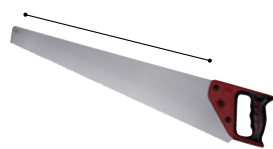

FB14  
A: 60 cm

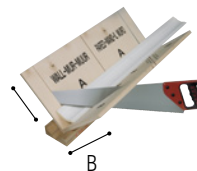

FB300  
A: 29,7 cm - B: 29,1cm

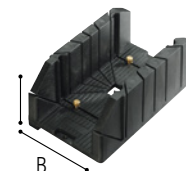

FB13  
A: 12,5 cm - B: 15,5 cm



FB10  
A: 27,5 cm - B: 22 cm



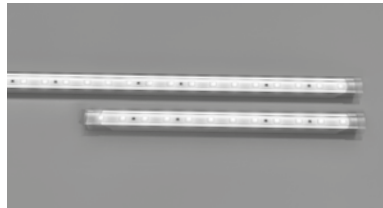

**LOW LUMEN LED BARS**

**IL004-001** 26 x 2 x 1,5 cm   
**IL004-002** 114,5 x 2 x 1,5 cm

IP50 - 24V  
 warm white 2700-2900K  
 2 clips incl.  
 CRI: 80  
 Light output / meter: +/- 100Lm  
 Power / meter: +/- 4W  
 Life span: +/- 30.000 hours



**HIGH LUMEN LED BARS**

**IL004-006** 26 x 2 x 1,5 cm   
**IL004-007** 114,5 x 2 x 1,5 cm

IP50 - 24V  
 warm white 2700-2900K  
 2 clips incl.  
 CRI: 80  
 Light output / meter: +/- 500Lm  
 Power / meter: +/- 10.5W  
 Life span: +/- 30.000 hours



**LED DRIVER**

**IL004-013** 30,5 x 3 x 1,7 cm  
 IP20 - 60W  
 24VDC - 200-240VAC  
 Class II (double insulated)



**1-10V DIMMABLE MODULE**

**IL004-009** 16 x 4,7 x 2,2 cm  
 IP40 - 240W (<10A)  
 12-24VDC

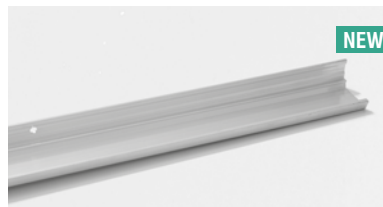

**ALUMINIUM SUPPORT**

**IL004-008**   
 200 x 2 x 3 cm

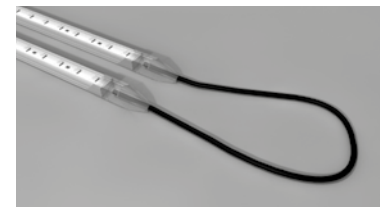

**CABLES TWO CONNECTIONS**

**IL004-004** 12,5 cm  
**IL004-005** 100 cm



**CABLE ONE CONNECTION**

**IL004-010** 100 cm  
 DRIVER > LED BAR

# LED BARS

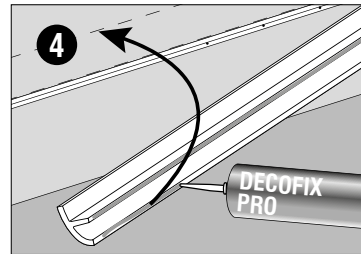
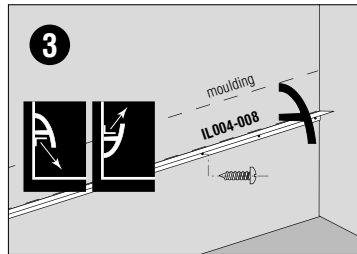
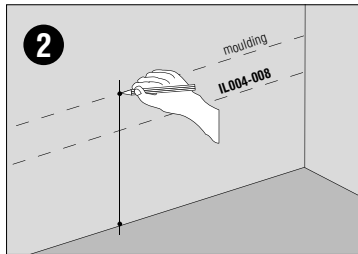
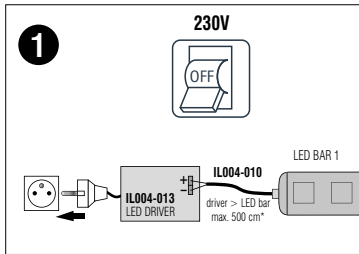

5

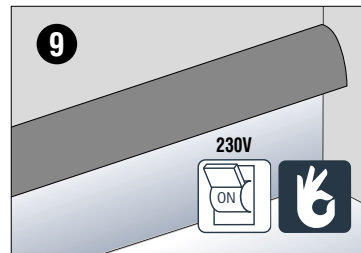
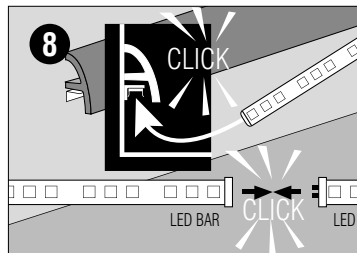
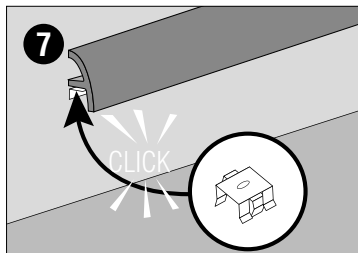
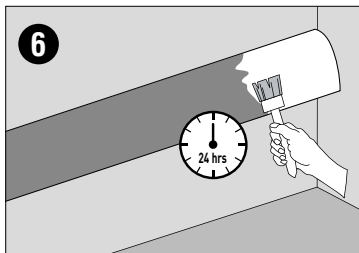



### pl

- Ponad 40 lat międzynarodowego doświadczenia
- Dostępne szkolenia instalacyjne – na stronie internetowej i w siedzibie
- Pliki 2D i 3D dostępne na stronie [www.oracdecor.com](http://www.oracdecor.com)
- Zaangażowani partnerzy na całym świecie
- Serwis próbek dla profesjonalistów
- Doradztwo techniczne od naszych specjalistów

### fr

- Plus de 40 ans d'expérience internationale
- Possibilités de formation à l'installation tant chez ORAC que sur site
- Fichiers 2D et 3D disponibles sur [www.oracdecor.com](http://www.oracdecor.com)
- Des partenaires mondiaux dévoués
- Un service d'échantillonnage simple et efficace
- Des conseils professionnels accompagnant votre projet

### en

- More than 40 years of international expertise
- In house and on site installation training available
- 2D and 3D files available on [www.oracdecor.com](http://www.oracdecor.com)
- Dedicated worldwide partners
- Sample service for professionals
- Technical advice from our in house experts

### ru

- Более 40 лет международного опыта
- Обучение монтажу в ORAC и на объектах
- 2D и 3D модели доступны на [www.oracdecor.com](http://www.oracdecor.com)
- Преданные партнеры по всему миру
- Предоставление образцов для профессионалов
- Экспертная техническая поддержка

### ar

- أكثر من ٤٠ سنة خبرة عالمية
- إمكانية التدريب على التركيب في مقر أوراك أو في الموقع
- ملفات ثنائية وثلاثية الأبعاد متوفرة على موقع [www.oracdecor.com](http://www.oracdecor.com)
- شركاء ملتزمين في جميع أنحاء العالم
- خدمة عينات سهلة وفعالة
- استشارات تقنية من خبراءنا



### **pl**

Produkty z kolekcji Ulf Moritz, Luxxus i Axxent nadają się do instalacji na zewnątrz.

Instrukcja klejenia na stronach 150-151.

Przy montażu na zewnątrz musi być zastosowana specjalna warstwa wierzchnia.

### **fr**

Les produits Ulf Moritz, Luxxus ainsi que les produits Axxent conviennent pour l'extérieur.

Instructions d'installation, voir pg. 150 - 151.

Ces produits doivent être parachevés avec une peinture spéciale pour extérieur.

### **en**

All Ulf Moritz, Luxxus and Axxent products can be used for exterior applications.

Gluing instructions on pg. 150 - 151.

The products have to be painted with a special coating for outside use.

### **ru**

Вся продукция Ulf Moritz, Luxxus и Axxent может применяться для оформления фасада.

Информация по использованию клея стр. 150-151

Продукция должна быть окрашена специальными красителями для наружного применения

### **ar**

يمكن إستعمال جميع اصناف أولف موريتز، لوكسس وأكسنت في الخارج.  
تعليمات اللصق صفحة 150 - 151.  
يجب دهن القوالب بطلاء خاص للإستخدام الخارجي.

**W CELU UZYSKANIA PORADY  
PROSIMY O KONTAKT**

**CONTACTEZ-NOUS  
POUR DES CONSEILS**

**CONTACT US FOR ADVISE**

**Свяжитесь с нами  
при возникновении  
вопросов**

**إتصلوا بنا للإستشارات**

Inner corner | Narożnik wewnętrzny | Coin intérieur | Внутренний угол | زاوية داخلية

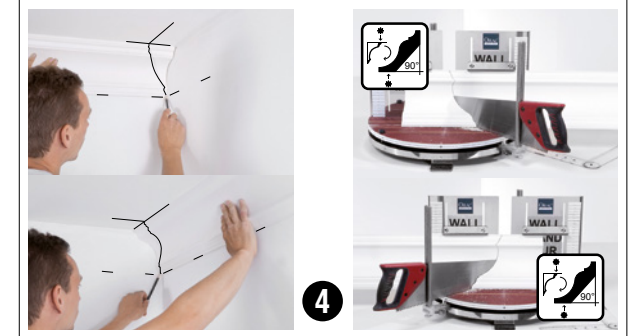
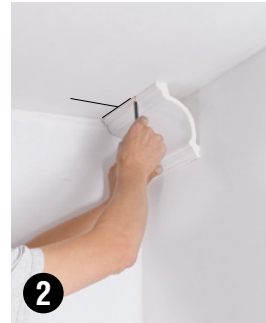

Outer corner | Narożnik zewnętrzny | Coin extérieur | Наружный угол | زاوية خارجية

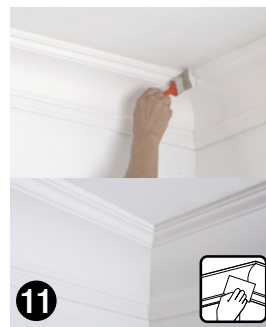
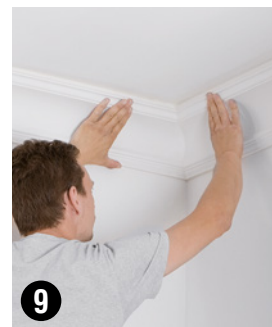
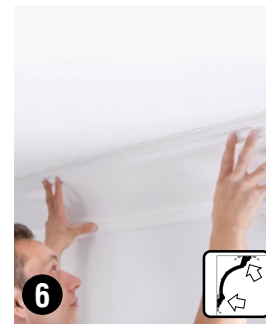
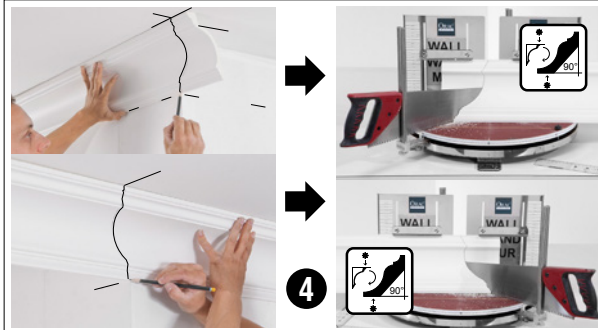

Stop mitre  
 Wykończenie  
 Arrêts  
 قص مشطوب

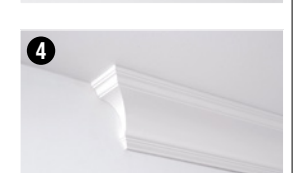

## Słowa Kluczowe

Aksesoria	148-153
Axent	62
Basixx	62
Boazeria	108,131
Cokoły	128, 143-145
DecoFix Extra	150, 151
DecoFix Hydro	150, 151
DecoFix Pro	150, 151
Durofoam®	63
Duropolymer®	63
Elementy dekoracyjne	141-143
Frontony	132
Głowice	143-145
Gwarancja	150, 160
Gzysmy	80-99
Instalacja	156
Instalacja na zewnątrz	155
Kable	152, 153
Kinkiety	135
Kleje	105, 151
Kolekcja Ulf Moritz	62, 64-79
Kolumny	143-145
Kopuły	140
Listwy oświetleniowe	118-124, 152-153
Listwy przypodłogowe	112-117
Luxus	62
Moduły oświetleniowe	152, 153
Narożniki do paneli	109, 110
Nisze	133
Obudowy biblioteczne	134, 135
Obudowy drzwiowe	128-129
Obudowy kominków	133
Orac Flex	98, 111, 117
Ozdoby sufitowe	140
Panele	130
Panele drzwiowe	130
Panele LED	152, 153
Pilastry	146
Pily	151
Pistolet do kleju	151
Poliuretan	63
Profile	100-111
Profile gięte	98, 111, 117
Projekty	154
Przymiar do cięcia Variomatic	151
Purotouch®	63
Rozety	136-139
Skrzynki uciosowe	151
Standardy przeciwpożarowe	160
Wsporniki	147

## Mots Clés

Accessoires	148-153
Applications extérieures	155
Appliques	135
Axent	62
Barres LED	152, 153
Basixx	62
Boîte à onglets	151
Byblos	134, 135
Chapiteaux	143-145
Cheminées décoratives	133
Cimaises	100-111
Coins pour cimaises	109, 110
Colle d'installation	150, 151
Colonnes	143-145
Consoles	147
Corniches	80-99
Coupoles	140
Dalles de plafond	140
DecoFix Extra	150, 151
DecoFix Hydro	150, 151
DecoFix Pro	150, 151
Durofoam®	63
Duropolymer®	63
Éclairage indirect	118-124, 152-153
Éléments décoratifs	141-143
Encadrements de portes	128-129
Frontons	132
Garantie	150, 160
Installation	156
Lambris	108, 131
Luxus	62
Moulures flexibles	98, 111, 117
Niches	133
Normes anti-incendie	160
Orac Flex	98, 111, 117
Panneaux	130
Panneaux de portes	130
Pistolet à colle	151
Plinthes	112-117
Polyuréthane	63
Projets	154
Purotouch®	63
Rosaces	136-139
Scie	151
Socles	128, 143-145
Transfo	152, 153
Ulf Moritz for Orac Decor®	62, 64-79
Variateur	152, 153
Variomatic	151

## Key Words

Accessories	148-153
Adhesive	105, 151
Axent	62
Basixx	62
Byblos	134, 135
Capitals	143-145
Ceiling roses	136-139
Ceiling tiles	140
Columns	143-145
Contract	154
Corbels	147
Cornice mouldings	80-99
Deco elements	141-143
DecoFix Extra	150, 151
DecoFix Hydro	150, 151
DecoFix Pro	150, 151
Decorative mantel pieces	133
Dimming module	152, 153
Domes	140
Door frames	128-129
Door panels	130
Driver	152, 153
Durofoam®	63
Duropolymer®	63
Exterior applications	155
Fire retardant standards	160
Fixtures	135
Flexible mouldings	98, 111, 117
Glue	150, 151
Glue pistol	151
Guarantee	150, 160
Indirect lighting	118-124, 152-153
Installation	156
LED bars	152, 153
Luxus	62
Mitre boxes	151
Niches	133
Orac Flex	98, 111, 117
Panel mouldings	100-111
Panelling	130
Panels moulding corners	109, 110
Pediments	132
Pilasters	146
Polyurethane	63
Purotouch®	63
Saw	151
Skirting boards	112-117
Socles	128, 143-145
Ulf Moritz for Orac Decor®	62, 64-79
Variomatic	151
Wainscoting	108,131

## Список ключевых слов

Axent	62
Basixx	62
DecoFix Extra	150, 151
DecoFix Hydro	150, 151
DecoFix Pro	150, 151
Decorative mantel pieces	133
Dimming module	152, 153
Durofoam®	63
Duropolymer®	63
LED Driver	152, 153
Luxus	62
Polyurethane	63
Purotouch®	63
Ulf Moritz для Orac Decor®	62, 64-79
Библиотечные системы	134, 135
Гарантия	150, 160
Гибкие модели Orac Flex	98, 111, 117
Гибкие молдинги	98, 111, 117
Дверное обрамление	128-129
Дверные панели	130
Декоративные элементы	141-143
Капители	143-145
Карнизы	80-99
Клей	105, 151
Колонны	143-145
Кронштейны	147
Купола	140
Молдинги	100-111
Монтаж	156
Наружное применение	155
Ниши	133
Облицовочные панели	108,131
Основания	128, 143-145
Панели	130
Пила	151
Пилястры	146
Пистолет для выдавливания клея	151
Плинтусы	112-117
Потолочные плиты	140
Потолочные розетки	136-139
Принадлежности	148-153
Проекты	154
Сандрики	132
Светильники	135
Светодиодный вкладыш	152, 153
Скрытое освещение	118-124, 152-153
Стандарты пожаробезопасности	160
Стусло	151
Угловые элементы молдингов	109, 110

155	إستعمال خارجي
143-141	أصناف للزينة
153-152, 124-118	إضاءة غير مباشرة
129-128	إطارات للأبواب
145-143	أعمدة
146	أعمدة مسطحة للجدران
132	أقواس
62	أكسنت
130	أنواع
130	أنواع للأبواب
140	أنواع للسقوف
117, 111, 98	أوراك فليكس
79-64, 62	أولف موريتز لأوراك ديكور®
63	بوليورثين
135, 134	بيلوس
62	بيركس
63	بيوروتاتش®
156	تركيب
131, 108	تلييسة جدار
63	دوروفوليمر®
63	دوروفوم®
151, 150	ديكوفيكس إكسترا
151, 150	ديكوفيكس برو
151, 150	ديكوفيكس هايدرو
147	روف
110, 109	زوايا لقراب الجدران
151	علب قص
151	علب قص بزواية قابلة للتعديل
140	قَب
153, 152	قضايا LED
145-143, 128	قواعد أعمدة
111-100	قوالب للجدران
117, 111, 98	قوالب مرنة
99-80	كرائيش
160, 150	كفالة
153-148	لوازم
62	لوكسس
133	محارِب
153, 152	محول
151	مسدس للمواد اللاصقة
154	مشروع
135	مصابيح للجدران
160	معايير مقاومة الإحتراق
151	منشار
151, 105	مواد لاصقة
133	مواقد زينية
117-112	نعلات
153, 152	وحدات تخفيف
139-136	ورديات للسقوف,

<b>B</b>		C305 + C211	83	C370	67, 90	CX107	96	<b>D</b>		<b>F</b>	
B401	147	C305 + C213	83	C371	66, 125	CX108	94	D120	132	F10	140
B404	147	C307	90	C372	66, 125	CX109   CX109F	94	D140	132	F11	140
B408	147	C307 + C307A	90	C373   C373F	68, 123	CX110   CX110F	94	D161	132	F12	140
B409	147	C308   C308F	91	C374   C374F	66, 123	CX111	93	D170	132	F30	130, 140
B410	147	C321   C321F	85	C400	83	CX112	94	D200	128, 141	F31	140
B413	147	C322   C322F	83	C402   C402F	85	CX115	93	D210	128, 141	FB10	151
B414	147	C331   C331F	83	C422	89	CX123	95	D300	128, 134	FB13	151
B417	147	C332	85, 91	C602   C602F	83	CX124   CX124F	94	D310	128, 134	FB14	151
		C333   C333F	86	C900	89, 125	CX126	95	D320	146	FB15	151
		C334   C334F	88	C901   C901F	88, 125	CX127   CX127F	96	D330LR	128	FB300	151
		C335	91, 160	C902   C902F	85, 125	CX128	96	D400	132	FDP100	151
		C336	91	C990	88, 90	CX129	96	D401	132	FDP500	150, 151
<b>C</b>		C337	89	C990 + 2x P9900	88, 90	CX132   CX132F	92, 114	D402	132	FDP600	150, 151
C200   C200F	84	C338	89	C990 + P9900	88, 90	CX133	93, 114	D500	130	FDP700	150, 151
C201   C201F	85	C338A	89	C990 + P9901	88, 90	CX134	108	D503	130	FX200	150, 151
C211   C211F	85	C338B	59, 89	C991	70, 86, 87, 125	CX136	95	D504	130	FX210	150, 151
C212   C212F	84	C339   C339F	87	C991 + 2x P9900	86, 87	CX141	95	D506	130		
C213   C213F	84	C340	86, 91	C991 + P9900	86, 87	CX142	95	D507	130		
C214   C214F	84	C341   C341F	84	CB500	97	CX143	95	D62	136, 141	<b>G</b>	
C215   C215F	83	C342	87	CB501	97	CX148   CX148F	93	DX119-2300	104, 128	G40	141
C216   C216F	85	C343	90	CB502	97	CX149	93	DX121-2300	104, 128	G42	141
C217   C217F	85, 88	C344	91	CB503	97	CX150	93	DX157-2300	92, 107, 114, 129	G70	72, 142
C218   C218F	87	C351	120	CB510	97	CX151	94	DX159-2300	92, 107, 114, 129	G71	71, 143
C219	89	C352	120	CB511	97	CX152	94	DX162-2300	92, 106, 114, 129	G72	72, 73, 142
C220   C220F	84	C353	82	CB512	97	CX153	94	DX163-2300	92, 107, 115, 129	G73L	72, 142
C230   C230F	82	C354	82, 99	CB520	97	CX154	93	DX168-2300	92, 107, 116, 129	G73R	72, 142
C240   C240F	84	C355	82	CB521	97	CX160	92	DX170-2300	105, 128	G74L	72, 142
C250   C250F	82	C356	82	CB522	97	CX161	92			G74R	72, 142
C260   C260F	82	C357	120	CB523	97					G75	71, 143
C300	88	C358	120	CB530	97					G76	71, 143
C301   C301F	89	C360	82	CB531	97					G77	72, 138, 142
C302   C302F	86	C361	121	CX100   CX100F	95					G78	72, 142
C303   C303F	87	C362	121	CX101	95					GB02	147
C304   C304F	86	C364	121	CX106	96						
C305	83										

GB03	147	K1132	144	K4131	143	P3071	67, 105	PX114	107	R50	137
GB04	147	K1141	145	K4132	143	P4020   P4020F	102, 109	PX116	106	R52	138
		K1142	144	KIT KX001	128	P4020A	109	PX117	106	R61	137
<b>И</b>		K1151	145	KIT KX003	128	P5020   P5020F	104, 109	PX120   PX120F	106, 110	R64	139
		K1152	144			P5020B	109, 141	PX120A	110	R66	138
H100A	133	K200	135, 146	<b>L</b>		P5020B	109	PX131	106	R70	71, 138
H100B	133	K201	135, 146			P5021   P5021F	102	PX144   PX144F	106	R73	139
H100C	133	K201LR	146	L504	135	P5050	105	PX145	106	R76	138
H101A	133	K202	135, 146	L505	135	P5051	103	PX146	107	R77	138
H101B	133	K2131	145			P6020   P6020F	103	PX147	108, 131		
		K2132	144	<b>M</b>		P7010   P7010F	104	PX164	93, 108	<b>S</b>	
<b>I</b>		K220	146			P7020   P7020F	105	PX169	108, 131		
		K221	146	M9010A	134	P7030   P7030F	104			SX104	116
IL004-001	152, 153	K223	146	M9010B	134	P7040   P7040F	103	<b>R</b>		SX105   SX105F	115
IL004-002	152, 153	K240	146	M9010C	134	P7070   P7070F	103			SX118   SX118F	116
IL004-004	152, 153	K241	146	M9010LR	134	P7080	105	R07	136	SX122	114
IL004-005	152, 153	K250	146			P801C	109	R08	136	SX125	114
IL004-006	152, 153	K251	146	<b>N</b>		P8020   P8020F	103, 109	R09	137	SX137	115
IL004-007	152, 153	K253	146			P8030   P8030F	102, 109	R10	136	SX138	116
IL004-008	152, 153	K254	146	N503	133	P8030C	109	R11	136	SX155   SX155F	115
IL004-009	152, 153	K255	146	N504	133	P8030D	109, 110	R12	136	SX156	116
IL004-010	152, 153	K3001	145	N510	133	P8040   P8040F	104	R13	137	SX165   SX165F	114
IL004-013	152, 153	K3002	144	N520	133	P8050   P8050F	29, 105	R14	137	SX167	116, 122
		K3101	145			P8060   P8060F	102	R17	137		
<b>K</b>		K3102	144	<b>P</b>		P9010   P9010F	104, 128, 134	R18	137	<b>T</b>	
		K3111	145			P9020   P9020F	104	R22	139		
K1001	145	K3112	144	P101A	109	P9040   P9040F	102	R23	139	TF02	147
K1002	144	K3141	145	P1020   P1020F	102, 109	P9050   P9050F	102	R24	139		
K1101	145	K3142	144	P20	109, 141	P9900   P9900F	103	R27	139		
K1102	144	K3151	145	P201A	109	P9901   P9901F	103	R28	138		
K1111	145	K3152	144	P2020   P2020F	102, 109	PB513	97	R31	137		
K1112	144	K3201	145	P21	109, 141	PX102	107	R35	136		
K1121	145	K3202	144	P3020   P3020F	103, 109	PX103   PX103F	106, 110	R38	139		
K1122	144	K4121	143	P3020A	109	PX103A	110	R40	139		
K1131	145	K4122	143	P3070	67, 105	PX113	107	R46	138		



#### SPECIAL THANKS TO

't Goude Hooft, Intera /Gilbert Comhair - Rabo Bank, MEMO/Harry Karel - The Hamptons, Kissy Vandenplas - Berto , Winny Vangroenweghe - Pand 16, Cheops - Veerle de Niel - Lan Lan, Marisa Gallo - Casa Decor, Beatriz Silveira, Manuel Nuñez y Sergio Moreno, Guillermo Garcia-Hoz, Jean Porsche - Northsea Penthouse, Ann Gryp - House of Porters - Items Knokke - RR Interieur - 't Casteelken - Wildspirit - Sigisbert Engelbosch - Hotel Das Tegernsee - the ORAC team

#### PHOTOGRAPHY BY

Verne Photography, Jürgen de Witte, [www.bartvanleuven.com](http://www.bartvanleuven.com)

#### REGISTERED CTM DESIGN N°

C335/000995576-0001 - C336/1035273-0001 - C337/1810706-0001 - C338/1978214-0001 - C338A/002341727-0007 - C338B/002341727-0006 - C339/1978214-0002 - C340/1978214-0003 - C341/002524769-0001 - C342/002524769-0002 - C343/002524769-0003 - C344/002524769-0004 - C351/000257464-0003 - C352/000257464-0004 - C353/000257464-0005 - C354/000257464-0006 - C355/000257464-0007 - C356/000257464-0008 - C361/1890526-0001 - C362/1890526-0002 - C363/1890526-0003 - C364/1890526-0004 - C370/2088880-0001 - C371/2088880-0002 - C372/2088880-0003 - C373/002524769-0005 - C374/002524769-0006 - C990/000995576-0002 - C991/002524769-0007 - CB500/1035273-0006 - CB501/1035273-0005 - CB502/1035273-0007 - CB503/1890526-0005 - CB510/1035273-000 - CB511/1035273-0003 - CB512/1890526-0007 - CB523/1035273-0002 - CB530/1890526-0008 - CB531/1890526-0009 - CX160/1790163-001 - CX161/1790163-0002 - D330/002524769-0013 - DX159-2300/1790163-0003 - DX162-2300/1790163-0004 - DX163-2300/1790163-0005 - DX168-2300/002341727-0004 - DX170-2300/002524769-0008 - G70/002158089-0001 - G71/002158089-0002 - G72/002158089-0003 - G73/002158089-0004 - G75/002524769-0009 - G76/002524769-0010 - G77/002524769-0011 - G78/002524769-0012 - P3020A/002341727-0005 - P3070/2088880-0004 - P3071/2088880-0005 - P5050/000257464-0001 - P5051/000257464-0002 - P8050/000995576-0003 - P8060/1810706-0002 - P9900/000995576-0004 - P9901/000995576-0005 - PB513/1890526-0006 - PX147/002341727-0003 - PX164/1790163-0006 - PX169/002341727-0002 - R70/2088880-0006 - SX156/000995576-0006 - SX165/002341727-0001 - SX167/2088880-0007

Guarantee terms and conditions apply if provided installation instructions have been followed to the letter.

Fire retardant standards. In many interiors and projects strict fire regulations are imposed. Therefore, ORAC has implemented a number of solutions depending on the country and its regulations. Please contact us for more information.

The information in this catalogue is without engagement. Changes and discrepancies in sizes or/and shapes against those stated in the catalogue can occur.

This catalogue and the design embodied within are protected by copyright law and international treaties. Unauthorized reproduction of the catalogue, any portion of it or the reproduction of the designs embodied therein may result in severe civil and criminal penalties and will be prosecuted to the maximum. Further legal information can be found on: [www.oracdecor.com/nl/disclaimer](http://www.oracdecor.com/nl/disclaimer).

All rights reserved. ©2014, ORAC nv

Concept & Graphics by King of Hearts and Gazeuse.be

*Reflecting*  
your  
*Imagination*

**ORAC HEADQUARTERS**

**NV ORAC SA**

Biekorfstraat 32  
8400 Ostend, BELGIUM  
T +32 (0)59 80 32 52  
F +32 (0)59 80 28 10  
info@oracdecor.com

**ORAC NEDERLAND**

T 0800-022 2125  
F 0800-022 2138  
nederland@oracdecor.com

**ORAC FRANCE**

T 0800-900 358  
F +32 (0)59 80 28 10  
france@oracdecor.com

**ORAC DEUTSCHLAND**

T 0800-181 3694  
F +32 (0)59 34 05 24  
deutschland@oracdecor.com

**ORAC (UK) LTD**

City Business Centre  
Brighton Road, Unit 8  
Horsham RH13 5BB - UK  
T +44 1403 240 102  
F +44 1403 258 686  
uk@oracdecor.com

**ORAC SLOVAKIA S.R.O.**

Kpt. Nalepku 6  
08271 Lipany - SK  
T +421 (0)514-891 581  
F +421 (0)514-573 595  
slovakia@oracdecor.com

**ORAC SPAIN**

T 900 99 32 89  
F +32 (0)59 80 28 10  
espana@oracdecor.com